

THIS COPY IS PROVIDED ON A RESTRICTED BASIS AND IS NOT TO BE USED IN ANY WAY DETRIMENTAL TO THE INTERESTS OF PANDUIT CORP.

NOTES:

- UL LISTED AND CSA CERTIFIED FOR:
 - 600V MAX VOLTAGE RATING
 - 221°F (105°C) MAX TEMP RATING (CSA).
 - 257°F (125°C) MAX. TEMP. RATING (UL).
 - STRANDED COPPER WIRE ONLY.
 - 6-12 LBS. INITIAL INSERTION/WITHDRAWL FORCE.
- MATERIAL:
 - STAMPING-CDA 260 BRASS, TIN PLATED
 - HOUSING-TYPE 66 NYLON
- DIMENSIONS IN BRACKETS ARE IN mm OR mm²
- COLORS ARE TRANSLUCENT
- PACKAGING:
 - STD -C=100, -L=50
 - BULK -M=1000, -D=500
- DNF10-250F1B IS UL APPROVED FOR USE WITH THE FOLLOWING WIRE COMBINATIONS:
 - #14, (2) #16, (2) #18
 TWIST WIRES TOGETHER BEFORE CRIMPING

PART NUMBER	PK	TAB SIZE	WIRE RANGE AWG (mm ²)	COLOR (note 4)	MAX. INSUL.	DIMENSIONS in.			STRIP LENGTH +1/32 (.08) - 0	TOOL CHART
						A ^{+0.03} _(.8)	B ^{+0.01} _(.3)	C ^{+0.02} _(.5)		
DNF18-250F1B	-C -M	.250 X .032	22-18 (0.5-1.5)	RED	.136 (3.45)	.84 (21.3)	.35 (8.9)	.22 (5.6)	9/32 (7.1)	CT-520 CT-1525
DNF18-205F1B	-L -M	.205/.187 X .032	22-18 (0.5-1.5)	RED	.136 (3.45)	.78 (19.8)	.31 (7.9)	.22 (5.6)		
DNF18-206F1B	-L -M	.205/.187 X .020	22-18 (0.5-1.5)	RED	.136 (3.45)	.78 (19.8)	.31 (7.9)	.22 (5.6)		
DNF18-187F1B	-C -M	.187 X .032	22-18 (0.5-1.5)	RED	.136 (3.45)	.78 (19.8)	.29 (7.4)	.16 (4.1)		
DNF18-188F1B	-C -M	.187 X .020	22-18 (0.5-1.5)	RED	.136 (3.45)	.78 (19.8)	.29 (7.4)	.16 (4.1)		
DNF14-250F1B	-C -M	.250 X .032	16-14 (1.5-2.5)	BLUE	.160 (4.06)	.84 (21.3)	.35 (8.9)	.22 (5.6)		
DNF14-205F1B	-C -M	.205/.187 X .032	16-14 (1.5-2.5)	BLUE	.160 (4.06)	.78 (19.8)	.31 (7.9)	.22 (5.6)		
DNF14-206F1B	-C -M	.205/.187 X .020	16-14 (1.5-2.5)	BLUE	.160 (4.06)	.78 (19.8)	.31 (7.9)	.22 (5.6)		
DNF14-187F1B	-C -M	.187 X .032	16-14 (1.5-2.5)	BLUE	.160 (4.06)	.78 (19.8)	.29 (7.4)	.18 (4.6)		
DNF14-188F1B	-C -M	.187 X .020	16-14 (1.5-2.5)	BLUE	.160 (4.06)	.78 (19.8)	.29 (7.4)	.18 (4.6)		
DNF10-250F1B	-L -D	.250 X .032	12-10 (4.0-6.0)	YELLOW	.220 (5.59)	.96 (24.4)	.35 (8.9)	.23 (5.8)	3/8 (9.5)	CT-1525

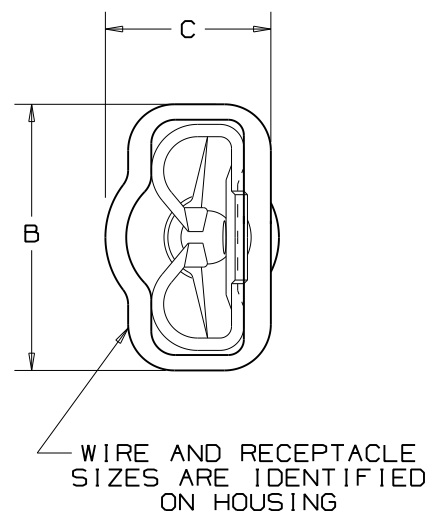
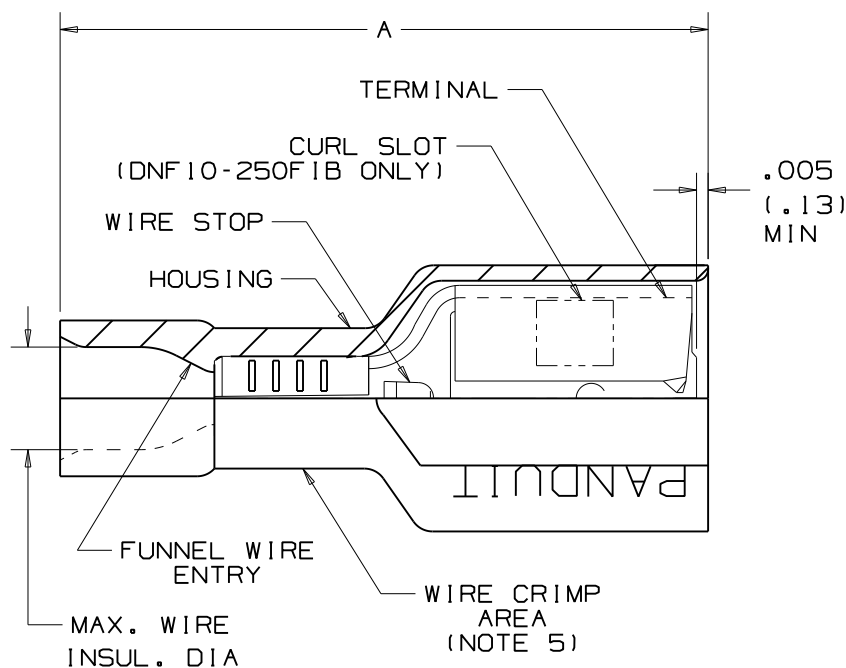

SEMIC TRADE
 SEMIC TRADE, s.r.o. www.semic.cz
 Volutova 2521/18 semic@semic.cz
 158 00 Praha 5 tel.: +420 251 625 331, 332, 377
 Czech Republic fax: +420 251 626 252, 393

FULLY INSULATED FEMALE DISCONNECTS
 .250 X .032, .205/.187 X .187/.188 X .032/.020

UNLESS OTHERWISE SPECIFIED,
 DIMENSIONAL TOLERANCES ARE:
 (.X) ±
 (.XX) ±
 (.XXX) ±
 ANGLES ±

UNLESS OTHERWISE SPECIFIED,
 ALL DIMENSIONS ARE GIVEN IN
 INCHES, THIRD ANGLE PROJECTION

REV	DATE	BY	CHK	DESCRIPTION	ECN #	PM	CUST
15	02/09	BCT		ADDED NOTE TO TWIST MULTIPLE WIRES TOGETHER PRIOR TO CRIMPING			
14	10/08	SRB		Changed packaging codes from "C" to "L"			

DRAWN BY	WJB	MAT'L:	
DATE	1/6/99		
CHK'D			
SCALE	NONE	DWG	B
DRAWING NO.	A41196	SIZE	