

EVALUATION KIT MANUAL  
AVAILABLE

# MAXIM

## 12V or Adjustable, High-Efficiency, Low IQ, Step-Up DC-DC Controller

### General Description

The MAX1771 step-up switching controller provides 90% efficiency over a 30mA to 2A load. A unique current-limited pulse-frequency-modulation (PFM) control scheme gives this device the benefits of pulse-width-modulation (PWM) converters (high efficiency at heavy loads), while using less than 110 $\mu$ A of supply current (vs. 2mA to 10mA for PWM converters).

This controller uses miniature external components. Its high switching frequency (up to 300kHz) allows surface-mount magnetics of 5mm height and 9mm diameter. It accepts input voltages from 2V to 16.5V. The output voltage is preset at 12V, or can be adjusted using two resistors.

The MAX1771 optimizes efficiency at low input voltages and reduces noise by using a single 100mV current-limit threshold under all load conditions. A family of similar devices, the MAX770–MAX773, trades some full-load efficiency for greater current-limit accuracy; they provide a 200mV current limit at full load, and switch to 100mV for light loads.

The MAX1771 drives an external N-channel MOSFET switch, allowing it to power loads up to 24W. If less power is required, use the MAX756/MAX757 or MAX761/MAX762 step-up switching regulators with on-board MOSFETs. An evaluation kit is available.

### Applications

- Positive LCD-Bias Generators
- Flash Memory Programmers
- High-Power RF Power-Amplifier Supply
- Palmtops/Hand-Held Terminals
- Battery-Powered Applications
- Portable Communicators

### Typical Operating Circuit

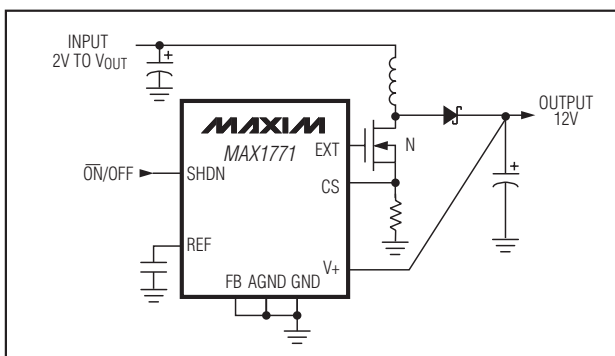

### Features

- ◆ 90% Efficiency for 30mA to 2A Load Currents
- ◆ Up to 24W Output Power
- ◆ 110 $\mu$ A (max) Supply Current
- ◆ 5 $\mu$ A (max) Shutdown Current
- ◆ 2V to 16.5V Input Range
- ◆ Preset 12V or Adjustable Output Voltage
- ◆ Current-Limited PFM Control Scheme
- ◆ Up to 300kHz Switching Frequency
- ◆ Evaluation Kit Available

### Ordering Information

PART	TEMP RANGE	PIN-PACKAGE
MAX1771CPA	0°C to +70°C	8 Plastic DIP
MAX1771CSA	0°C to +70°C	8 SO
MAX1771C/D	0°C to +70°C	Dice*
MAX1771EPA	-40°C to +85°C	8 Plastic DIP
MAX1771ESA	-40°C to +85°C	8 SO
MAX1771MJA	-55°C to +125°C	8 CERDIP**

\* Contact factory for dice specifications.

\*\* Contact factory for availability and processing to MIL-STD-883B.

### Pin Configuration

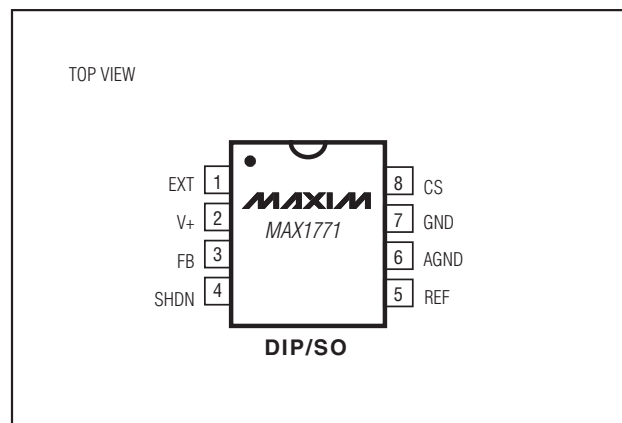

MAXIM

Maxim Integrated Products 1

For pricing, delivery, and ordering information, please contact Maxim/Dallas Direct! at 1-888-629-4642, or visit Maxim's website at [www.maxim-ic.com](http://www.maxim-ic.com).

MAX1771

# 12V or Adjustable, High-Efficiency, Low IQ, Step-Up DC-DC Controller

## ABSOLUTE MAXIMUM RATINGS

### Supply Voltage

V+ to GND .....-0.3V, 17V

EXT, CS, REF, SHDN, FB to GND .....-0.3V, (V+ + 0.3V)

GND to AGND.....0.1V, -0.1V

### Continuous Power Dissipation (T<sub>A</sub> = +70°C)

Plastic DIP (derate 9.09mW/°C above +70°C) .....727mW

SO (derate 5.88mW/°C above +70°C).....471mW

CERDIP (derate 8.00mW/°C above +70°C).....640mW

### Operating Temperature Ranges

MAX1771C\_A .....0°C to +70°C

MAX1771E\_A .....-40°C to +85°C

MAX1771MJA .....-55°C to +125°C

### Junction Temperatures

MAX1771C\_A/E\_A.....+150°C

MAX1771MJA .....+175°C

### Storage Temperature Range .....-65°C to +160°C

Lead Temperature (soldering, 10sec) .....+300°C

Stresses beyond those listed under "Absolute Maximum Ratings" may cause permanent damage to the device. These are stress ratings only, and functional operation of the device at these or any other conditions beyond those indicated in the operational sections of the specifications is not implied. Exposure to absolute maximum rating conditions for extended periods may affect device reliability.

## ELECTRICAL CHARACTERISTICS

(V+ = 5V, I<sub>LOAD</sub> = 0mA, T<sub>A</sub> = T<sub>MIN</sub> to T<sub>MAX</sub>, unless otherwise noted. Typical values are at T<sub>A</sub> = +25°C.)

PARAMETER	SYMBOL	CONDITIONS	MIN	TYP	MAX	UNITS	
Input Voltage Range		MAX1771 (internal feedback resistors)	2.0		12.5	V	
		MAX1771C/E (external resistors)	3.0		16.5		
		MAX1771MJA (external resistors)	3.1		16.5		
Minimum Start-Up Voltage			1.8	2.0		V	
Supply Current		V+ = 16.5V, SHDN = 0V (normal operation)		85	110	μA	
Standby Current		V+ = 10V, SHDN ≥ 1.6V (shutdown)		2	5	μA	
		V+ = 16.5V, SHDN ≥ 1.6V (shutdown)		4			
Output Voltage (Note 1)		V+ = 2V to 12V, over full load range, Circuit of Figure 2a	11.52	12.0	12.48	V	
Output Voltage Line Regulation (Note 2)		V+ = 5V to 7V, V <sub>OUT</sub> = 12V I <sub>LOAD</sub> = 700mA, Circuit of Figure 2a		5		mV/V	
Output Voltage Load Regulation (Note 2)		V+ = 6V, V <sub>OUT</sub> = 12V, I <sub>LOAD</sub> = 0mA to 500mA, Circuit of Figure 2a		20		mV/A	
Maximum Switch On-Time	t <sub>ON(max)</sub>		12	16	20	μs	
Minimum Switch Off-Time	t <sub>OFF(min)</sub>		1.8	2.3	2.8	μs	
Efficiency		V+ = 5V, V <sub>OUT</sub> = 12V, I <sub>LOAD</sub> = 500mA, Circuit of Figure 2a		92		%	
Reference Voltage	V <sub>REF</sub>	I <sub>REF</sub> = 0μA	MAX1771C	1.4700	1.5	1.5300	V
			MAX1771E	1.4625	1.5	1.5375	
			MAX1771M	1.4550	1.5	1.5450	
REF Load Regulation		0μA ≤ I <sub>REF</sub> ≤ 100μA	MAX1771C/E		4	10	mV
			MAX1771M		4	15	
REF Line Regulation		3V ≤ V+ ≤ 16.5V		40	100	μV/V	
FB Trip Point Voltage	V <sub>FB</sub>	MAX1771C	1.4700	1.5	1.5300	V	
		MAX1771E	1.4625	1.5	1.5375		
		MAX1771M	1.4550	1.5	1.5450		

# 12V or Adjustable, High-Efficiency, Low IQ, Step-Up DC-DC Controller

## ELECTRICAL CHARACTERISTICS (continued)

( $V_+ = 5V$ ,  $I_{LOAD} = 0mA$ ,  $T_A = T_{MIN}$  to  $T_{MAX}$ , unless otherwise noted. Typical values are at  $T_A = +25^\circ C$ .)

PARAMETERS	SYMBOL	CONDITIONS	MIN	TYP	MAX	UNITS	
FB Input Current	I <sub>FB</sub>	MAX1771C			±20	nA	
		MAX1771E			±40		
		MAX1771M			±60		
SHDN Input High Voltage	V <sub>IH</sub>	V <sub>+</sub> = 2V to 16.5V	1.6			V	
SHDN Input Low Voltage	V <sub>IL</sub>	V <sub>+</sub> = 2V to 16.5V			0.4	V	
SHDN Input Current		V <sub>+</sub> = 16.5V, SHDN = 0V or V <sub>+</sub>			±1	µA	
Current-Limit Trip Level	V <sub>CS</sub>	V <sub>+</sub> = 5V to 16V	MAX1771C/E	85	100	115	mV
			MAX1771M	75	100	125	
CS Input Current				0.01	±1	µA	
EXT Rise Time		V <sub>+</sub> = 5V, 1nF from EXT to ground		55		ns	
EXT Fall Time		V <sub>+</sub> = 5V, 1nF from EXT to ground		55		ns	

**Note 1:** Output voltage guaranteed using preset voltages. See Figures 4a–4d for output current capability versus input voltage.

**Note 2:** Output voltage line and load regulation depend on external circuit components.

## Typical Operating Characteristics

( $T_A = +25^\circ C$ , unless otherwise noted.)

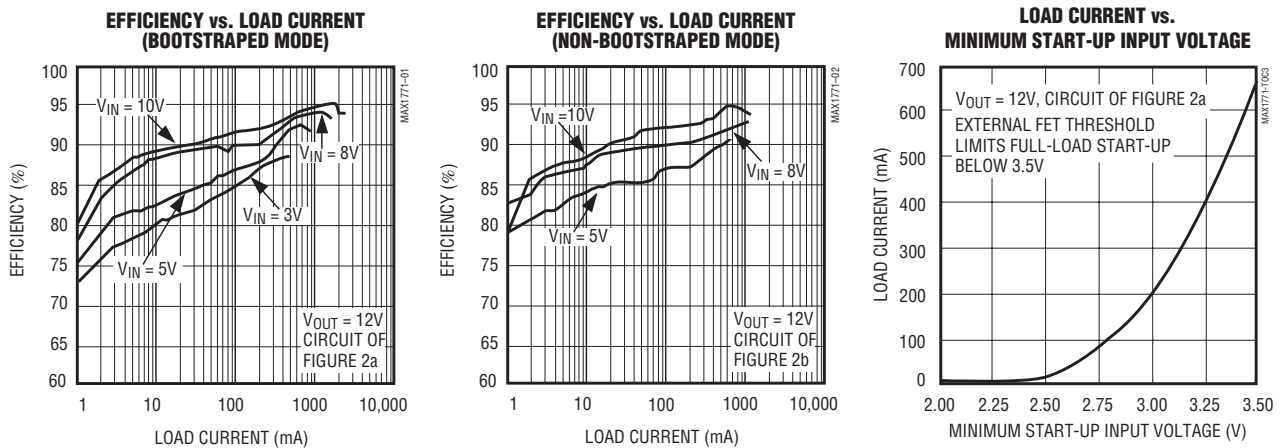

# 12V or Adjustable, High-Efficiency, Low IQ, Step-Up DC-DC Controller

## Typical Operating Characteristics (continued)

( $T_A = +25^\circ\text{C}$ , unless otherwise noted.)

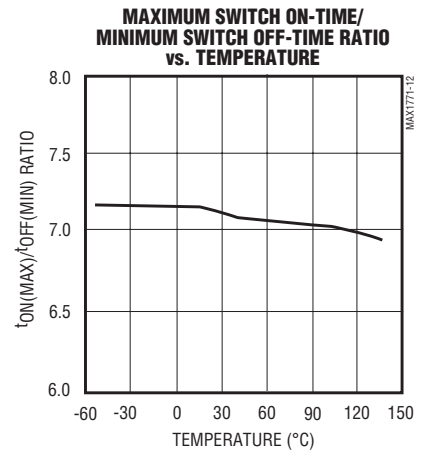
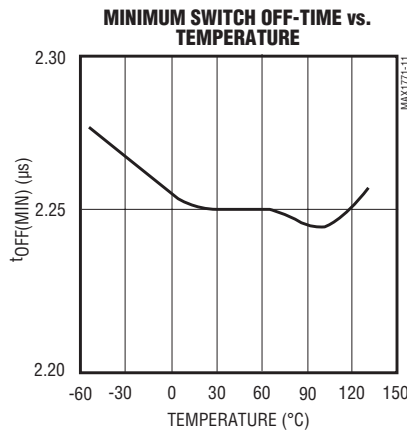
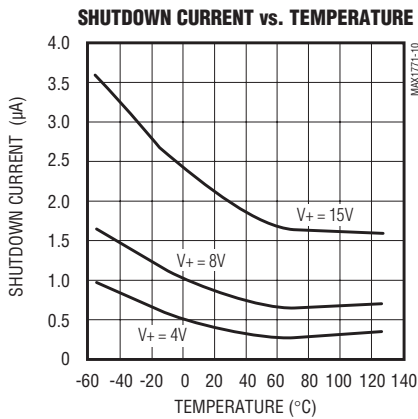
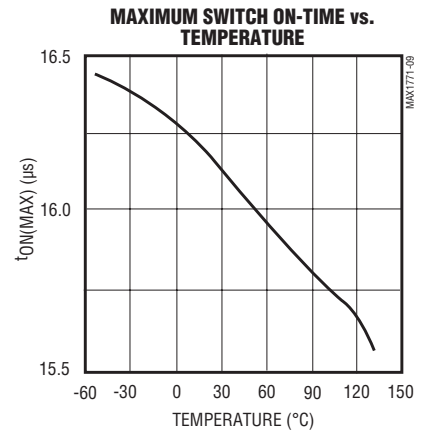
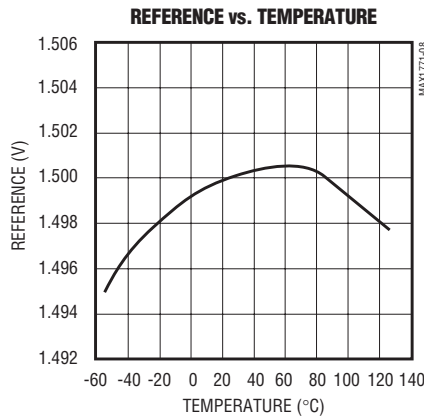
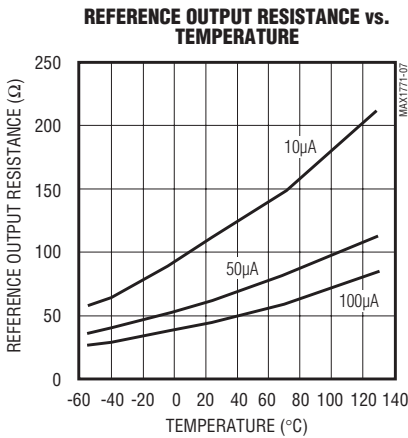
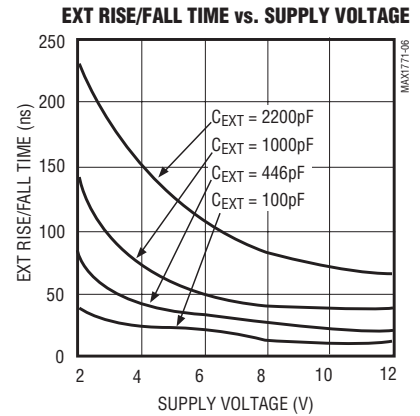
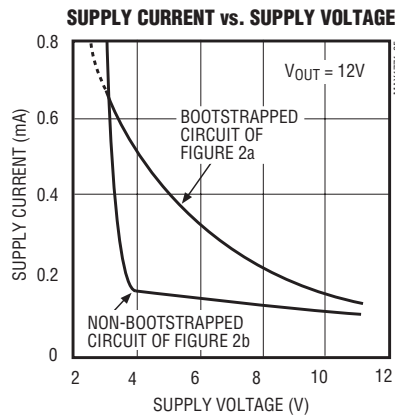
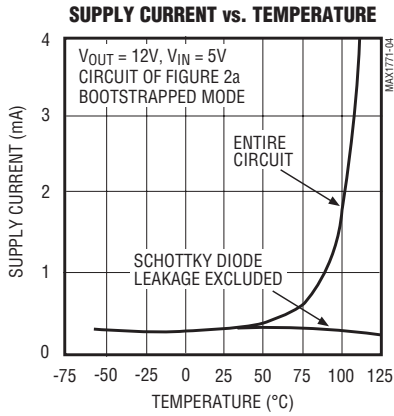

# 12V or Adjustable, High-Efficiency, Low IQ, Step-Up DC-DC Controller

MAX1771

## Typical Operating Characteristics (continued)

(Circuit of Figure 2a,  $T_A = +25^\circ\text{C}$ , unless otherwise noted.)

**HEAVY-LOAD SWITCHING WAVEFORMS**

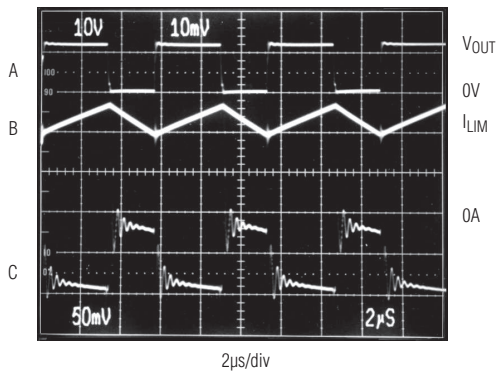

$V_{IN} = 5\text{V}$ ,  $I_{OUT} = 900\text{mA}$ ,  $V_{OUT} = 12\text{V}$   
 A: EXT VOLTAGE, 10V/div  
 B: INDUCTOR CURRENT, 1A/div  
 C:  $V_{OUT}$  RIPPLE, 50mV/div, AC-COUPLED

**MEDIUM-LOAD SWITCHING WAVEFORMS**

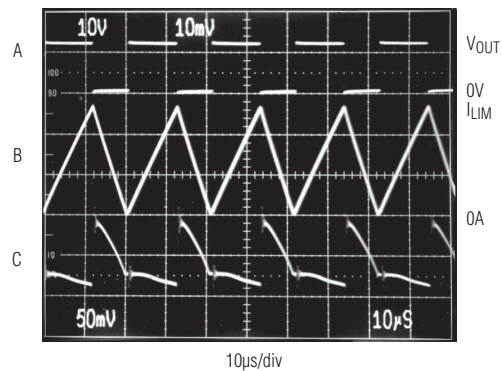

$V_{IN} = 5\text{V}$ ,  $I_{OUT} = 500\text{mA}$ ,  $V_{OUT} = 12\text{V}$   
 A: EXT VOLTAGE, 10V/div  
 B: INDUCTOR CURRENT, 1A/div  
 C:  $V_{OUT}$  RIPPLE, 50mV/div, AC-COUPLED

**LINE-TRANSIENT RESPONSE**

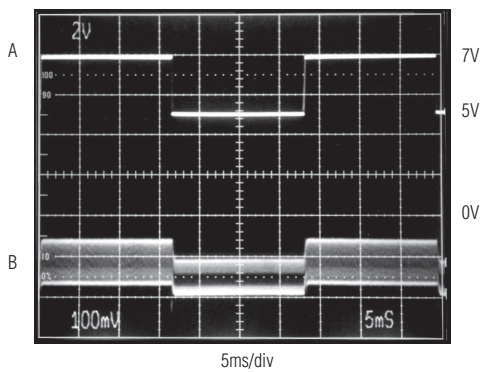

$I_{OUT} = 700\text{mA}$ ,  $V_{OUT} = 12\text{V}$   
 A:  $V_{IN}$ , 5V to 7V, 2V/div  
 B:  $V_{OUT}$  RIPPLE, 100mV/div, AC-COUPLED

**LOAD-TRANSIENT RESPONSE**

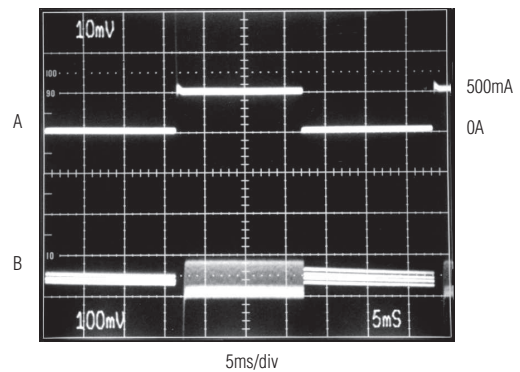

$V_{IN} = 6\text{V}$ ,  $V_{OUT} = 12\text{V}$   
 A: LOAD CURRENT, 0mA to 500mA, 500mA/div  
 B:  $V_{OUT}$  RIPPLE, 100mV/div, AC-COUPLED

# 12V or Adjustable, High-Efficiency, Low IQ, Step-Up DC-DC Controller

## Typical Operating Characteristics (continued)

(Circuit of Figure 2a,  $T_A = +25^\circ\text{C}$ , unless otherwise noted.)

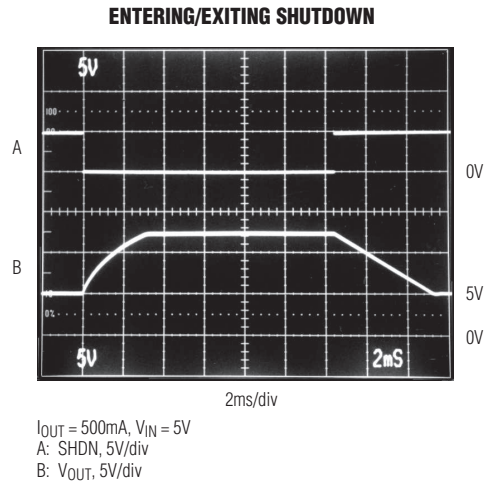

## Pin Description

PIN	NAME	FUNCTION
1	EXT	Gate Drive for External N-Channel Power Transistor
2	V+	Power-Supply Input. Also acts as a voltage-sense point when in bootstrapped mode.
3	FB	Feedback Input for Adjustable-Output Operation. Connect to ground for fixed-output operation. Use a resistor divider network to adjust the output voltage. See <i>Setting the Output Voltage</i> section.
4	SHDN	Active-High TTL/CMOS Logic-Level Shutdown Input. In shutdown mode, $V_{OUT}$ is a diode drop below V+ (due to the DC path from V+ to the output) and the supply current drops to 5 $\mu\text{A}$ maximum. Connect to ground for normal operation.
5	REF	1.5V Reference Output that can source 100 $\mu\text{A}$ for external loads. Bypass to GND with 0.1 $\mu\text{F}$ . The reference is disabled in shutdown.
6	AGND	Analog Ground
7	GND	High-Current Ground Return for the Output Driver
8	CS	Positive Input to the Current-Sense Amplifier. Connect the current-sense resistor between CS and GND.

# 12V or Adjustable, High-Efficiency, Low IQ, Step-Up DC-DC Controller

## Detailed Description

The MAX1771 is a BiCMOS, step-up, switch-mode power-supply controller that provides a preset 12V output, in addition to adjustable-output operation. Its unique control scheme combines the advantages of pulse-frequency modulation (low supply current) and pulse-width modulation (high efficiency with heavy loads), providing high efficiency over a wide output current range, as well as increased output current capability over previous PFM devices. In addition, the external sense resistor and power transistor allow the user to tailor the output current capability for each application. Figure 1 shows the MAX1771 functional diagram.

The MAX1771 offers three main improvements over prior pulse-skipping control solutions: 1) the converter operates with miniature (5mm height and less than 9mm diameter) surface-mount inductors due to its 300kHz switching frequency; 2) the current-limited PFM control scheme allows 90% efficiencies over a wide

range of load currents; and 3) the maximum supply current is only 110 $\mu$ A.

The device has a shutdown mode that reduces the supply current to 5 $\mu$ A max.

## Bootstrapped/Non-Bootstrapped Modes

Figure 2 shows the standard application circuits for bootstrapped and non-bootstrapped modes. In bootstrapped mode, the IC is powered from the output ( $V_{OUT}$ , which is connected to  $V+$ ) and the input voltage range is 2V to  $V_{OUT}$ . The voltage applied to the gate of the external power transistor is switched from  $V_{OUT}$  to ground, providing more switch gate drive and thus reducing the transistor's on-resistance.

In non-bootstrapped mode, the IC is powered from the input voltage ( $V+$ ) and operates with minimum supply current. In this mode, FB is the output voltage sense point. Since the voltage swing applied to the gate of the external power transistor is reduced (the gate swings from  $V+$  to ground), the power transistor's on-resistance

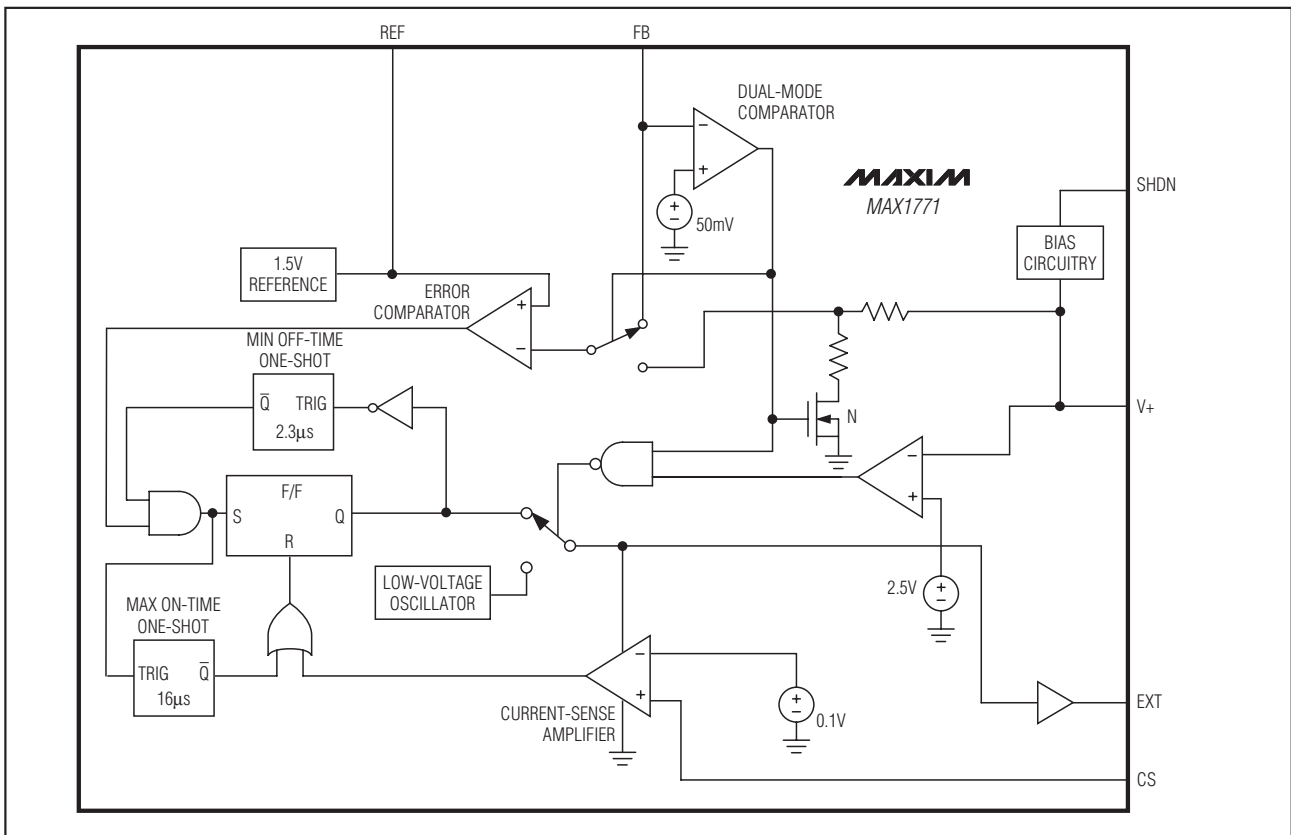

Figure 1. Functional Diagram



# 12V or Adjustable, High-Efficiency, Low IQ, Step-Up DC-DC Controller

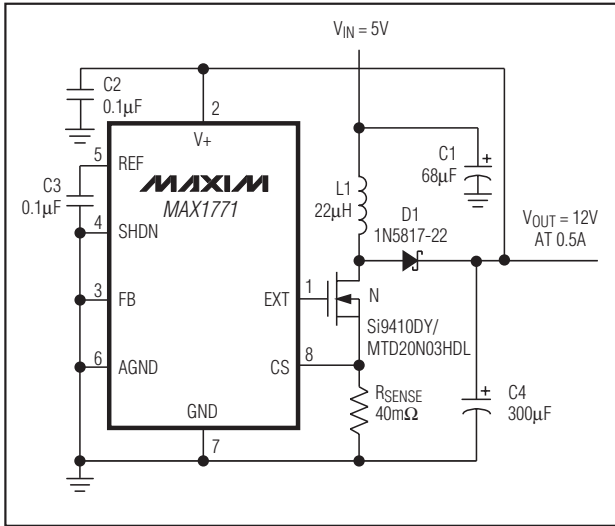

Figure 2a. 12V Preset Output, Bootstrapped

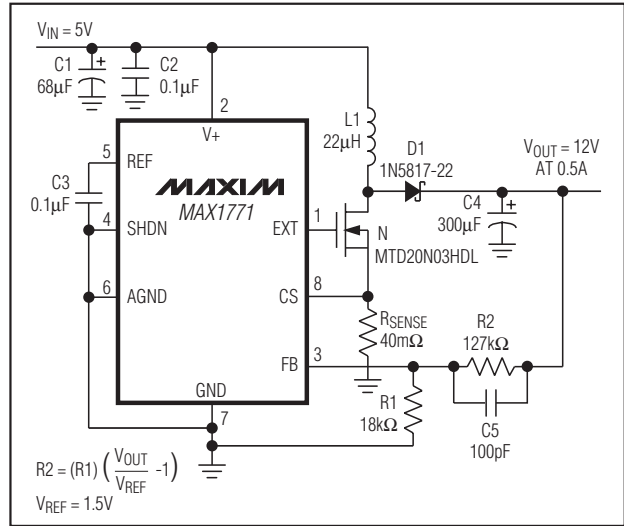

Figure 2b. 12V Output, Non-Bootstrapped

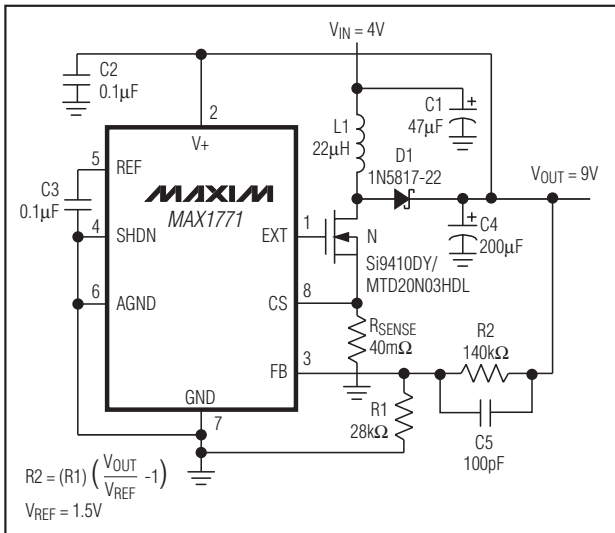

Figure 2c. 9V Output, Bootstrapped

increases at low input voltages. However, the supply current is also reduced because V+ is at a lower voltage, and because less energy is consumed while charging and discharging the external MOSFET's gate capacitance. The minimum input voltage is 3V when using external feedback resistors. With supply voltages below 5V, bootstrapped mode is recommended.

**Note:** When using the MAX1771 in non-bootstrapped mode, there is no preset output operation because V+ is also the output voltage sense point

for fixed-output operation. External resistors must be used to set the output voltage. Use 1% external feedback resistors when operating in adjustable-output mode (Figures 2b, 2c) to achieve an overall output voltage accuracy of ±5%. To achieve highest efficiency, operate in bootstrapped mode whenever possible.

## External Power-Transistor Control Circuitry

### PFM Control Scheme

The MAX1771 uses a proprietary current-limited PFM control scheme to provide high efficiency over a wide range of load currents. This control scheme combines the ultra-low supply current of PFM converters (or pulse skippers) with the high full-load efficiency of PWM converters.

Unlike traditional PFM converters, the MAX1771 uses a sense resistor to control the peak inductor current. The device also operates with high switching frequencies (up to 300kHz), allowing the use of miniature external components.

As with traditional PFM converters, the power transistor is not turned on until the voltage comparator senses the output is out of regulation. However, unlike traditional PFM converters, the MAX1771 switch uses the combination of a peak current limit and a pair of one-shots that set the maximum on-time (16µs) and minimum off-time (2.3µs); there is no oscillator. Once off, the minimum off-time one-shot holds the switch off for 2.3µs. After this minimum time, the switch either 1) stays off if the output is in regulation, or 2) turns on again if the output is out of regulation.



# 12V or Adjustable, High-Efficiency, Low IQ, Step-Up DC-DC Controller

The control circuitry allows the IC to operate in continuous-conduction mode (CCM) while maintaining high efficiency with heavy loads. When the power switch is turned on, it stays on until either 1) the maximum on-time one-shot turns it off (typically 16μs later), or 2) the switch current reaches the peak current limit set by the current-sense resistor.

The MAX1771 switching frequency is variable (depending on load current and input voltage), causing variable switching noise. However, the subharmonic noise generated does not exceed the peak current limit times the filter capacitor equivalent series resistance (ESR). For example, when generating a 12V output at 500mA from a 5V input, only 100mV of output ripple occurs using the circuit of Figure 2a.

### Low-Voltage Start-Up Oscillator

The MAX1771 features a low input voltage start-up oscillator that guarantees start-up with no load down to 2V when operating in bootstrapped mode and using internal feedback resistors. At these low voltages, the supply voltage is not large enough for proper error-comparator operation and internal biasing. The start-up oscillator has a fixed 50% duty cycle and the MAX1771 disregards the error-comparator output when the supply voltage is less than 2.5V. Above 2.5V, the error-comparator and normal one-shot timing circuitry are used. The low-voltage start-up circuitry is disabled if non-bootstrapped mode is selected (FB is not tied to ground).

### Shutdown Mode

When SHDN is high, the MAX1771 enters shutdown mode. In this mode, the internal biasing circuitry is turned off (including the reference) and  $V_{OUT}$  falls to a diode drop below  $V_{IN}$  (due to the DC path from the input to the output). In shutdown mode, the supply current drops to less than 5μA. SHDN is a TTL/CMOS logic-level input. Connect SHDN to GND for normal operation.

## Design Procedure

### Setting the Output Voltage

To set the output voltage, first determine the mode of operation, either bootstrapped or non-bootstrapped. Bootstrapped mode provides more output current capability, while non-bootstrapped mode reduces the supply current (see the *Typical Operating Characteristics*). If a decaying voltage source (such as a battery) is used, see the additional notes in the *Low Input Voltage Operation* section.

The MAX1771's output voltage can be adjusted from very high voltages down to 3V, using external resistors

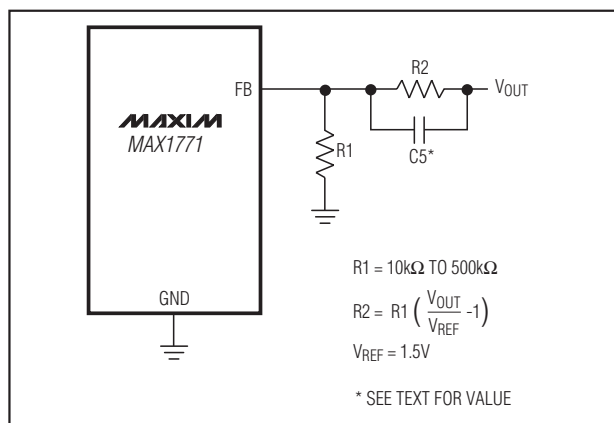

Figure 3. Adjustable Output Circuit

$R1$  and  $R2$  configured as shown in Figure 3. For adjustable-output operation, select feedback resistor  $R1$  in the 10kΩ to 500kΩ range.  $R2$  is given by:

$$R2 = (R1) \left( \frac{V_{OUT}}{V_{REF}} - 1 \right)$$

where  $V_{REF}$  equals 1.5V.

For preset-output operation, tie FB to GND (this forces bootstrapped-mode operation).

Figure 2 shows various circuit configurations for bootstrapped/non-bootstrapped, preset/adjustable operation.

### Determining $R_{SENSE}$

Use the theoretical output current curves shown in Figures 4a–4d to select  $R_{SENSE}$ . They were derived using the minimum (worst-case) current-limit comparator threshold value over the extended temperature range (-40°C to +85°C). No tolerance was included for  $R_{SENSE}$ . The voltage drop across the diode was assumed to be 0.5V, and the drop across the power switch  $r_{DS(ON)}$  and coil resistance was assumed to be 0.3V.

### Determining the Inductor (L)

Practical inductor values range from 10μH to 300μH. 22μH is a good choice for most applications. In applications with large input/output differentials, the IC's output current capability will be much less when the inductance value is too low, because the IC will always operate in discontinuous mode. If the inductor value is too low, the current will ramp up to a high level before the current-limit comparator can turn off the switch. The minimum on-time for the switch ( $t_{ON(min)}$ ) is

# 12V or Adjustable, High-Efficiency, Low IQ, Step-Up DC-DC Controller

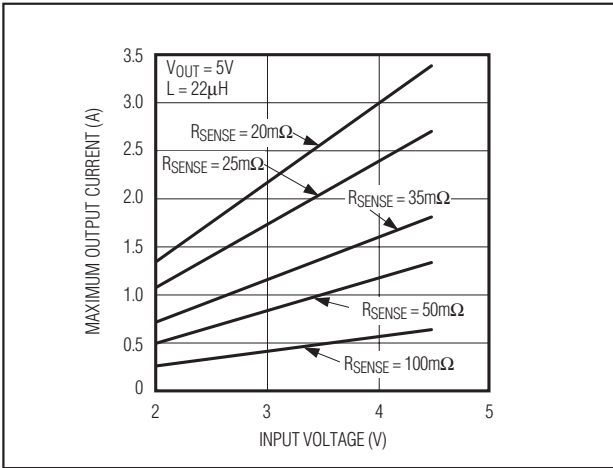

Figure 4a. Maximum Output Current vs. Input Voltage ( $V_{OUT} = 5V$ )

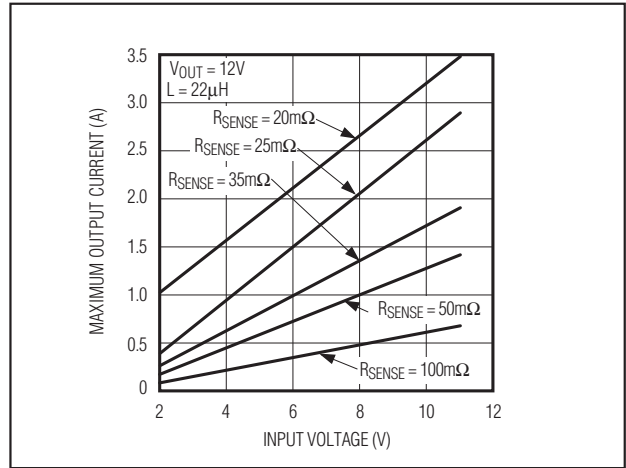

Figure 4b. Maximum Output Current vs. Input Voltage ( $V_{OUT} = 12V$ )

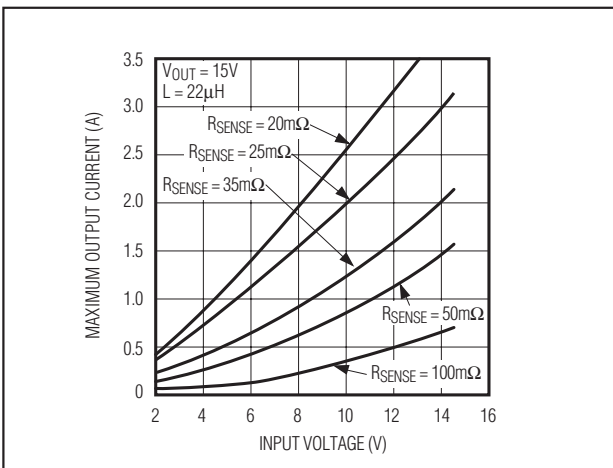

Figure 4c. Maximum Output Current vs. Input Voltage ( $V_{OUT} = 15V$ )

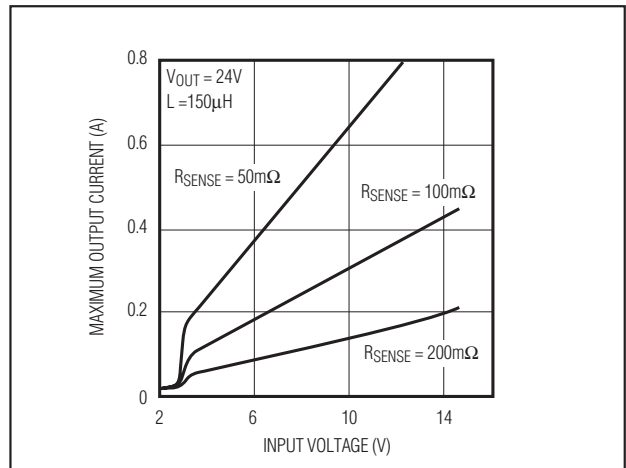

Figure 4d. Maximum Output Current vs. Input Voltage ( $V_{OUT} = 24V$ )

approximately  $2\mu s$ ; select an inductor that allows the current to ramp up to  $I_{LIM}$ .

The standard operating circuits use a  $22\mu H$  inductor. If a different inductance value is desired, select  $L$  such that:

$$L \geq \frac{V_{IN(max)} \times 2\mu s}{I_{LIM}}$$

Larger inductance values tend to increase the start-up time slightly, while smaller inductance values allow the coil current to ramp up to higher levels before the switch turns off, increasing the ripple at light loads.

Inductors with a ferrite core or equivalent are recommended; powder iron cores are not recommended for use with high switching frequencies. Make sure the inductor's saturation current rating (the current at which the core begins to saturate and the inductance starts to fall) exceeds the peak current rating set by  $R_{SENSE}$ . However, it is generally acceptable to bias the inductor into saturation by approximately 20% (the point where the inductance is 20% below the nominal value). For highest efficiency, use a coil with low DC resistance, preferably under  $20m\Omega$ . To minimize radiated noise, use a toroid, a pot core, or a shielded coil.

Table 1 lists inductor suppliers and specific recommended inductors.

# 12V or Adjustable, High-Efficiency, Low IQ, Step-Up DC-DC Controller

## Power Transistor Selection

Use an N-channel MOSFET power transistor with the MAX1771.

To ensure the external N-channel MOSFET (N-FET) is turned on hard, use logic-level or low-threshold N-FETs when the input drive voltage is less than 8V. This applies even in bootstrapped mode, to ensure start-up. N-FETs provide the highest efficiency because they do not draw any DC gate-drive current.

When selecting an N-FET, three important parameters are the total gate charge ( $Q_g$ ), on-resistance ( $r_{DS(ON)}$ ), and reverse transfer capacitance ( $CR_{SS}$ ).

$Q_g$  takes into account all capacitances associated with charging the gate. Use the typical  $Q_g$  value for best results; the maximum value is usually grossly over-specified since it is a guaranteed limit and not the measured value. The typical total gate charge should be 50nC or less. With larger numbers, the EXT pins may not be able to adequately drive the gate. The EXT rise/fall time varies with different capacitive loads as shown in the *Typical Operating Characteristics*.

The two most significant losses contributing to the N-FET's power dissipation are  $I^2R$  losses and switching losses. Select a transistor with low  $r_{DS(ON)}$  and low  $CR_{SS}$  to minimize these losses.

Determine the maximum required gate-drive current from the  $Q_g$  specification in the N-FET data sheet.

The MAX1771's maximum allowed switching frequency during normal operation is 300kHz; but at start-up, the maximum frequency can be 500kHz, so the maximum current required to charge the N-FET's gate is  $f(\max) \times Q_g(\text{typ})$ . Use the typical  $Q_g$  number from the transistor data sheet. For example, the Si9410DY has a  $Q_g(\text{typ})$  of 17nC (at  $V_{GS} = 5V$ ), therefore the current required to charge the gate is:

$$I_{GATE}(\max) = (500\text{kHz}) (17\text{nC}) = 8.5\text{mA}.$$

The bypass capacitor on  $V+$  (C2) must instantaneously furnish the gate charge without excessive droop (e.g., less than 200mV):

$$\Delta V+ = \frac{Q_g}{C2}$$

Continuing with the example,  $\Delta V+ = 17\text{nC}/0.1\mu\text{F} = 170\text{mV}$ .

Figure 2a's application circuit uses an 8-pin Si9410DY surface-mount N-FET that has 50m $\Omega$  on-resistance with 4.5V  $V_{GS}$ , and a guaranteed  $V_{TH}$  of less than 3V. Figure 2b's application circuit uses an MTD20N03HDL logic-level N-FET with a guaranteed threshold voltage ( $V_{TH}$ ) of 2V.

## Diode Selection

The MAX1771's high switching frequency demands a high-speed rectifier. Schottky diodes such as the 1N5817–1N5822 are recommended. Make sure the Schottky diode's average current rating exceeds the peak current limit set by  $R_{SENSE}$ , and that its breakdown voltage exceeds  $V_{OUT}$ . For high-temperature applications, Schottky diodes may be inadequate due to their high leakage currents; high-speed silicon diodes such as the MUR105 or EC11FS1 can be used instead. At heavy loads and high temperatures, the benefits of a Schottky diode's low forward voltage may outweigh the disadvantages of its high leakage current.

## Capacitor Selection

### Output Filter Capacitor

The primary criterion for selecting the output filter capacitor (C4) is low effective series resistance (ESR). The product of the peak inductor current and the output filter capacitor's ESR determines the amplitude of the ripple seen on the output voltage. Two OS-CON 150 $\mu\text{F}$ , 16V output filter capacitors in parallel with 35m $\Omega$  of ESR each typically provide 75mV ripple when stepping up from 5V to 12V at 500mA (Figure 2a). Smaller-value and/or higher-ESR capacitors are acceptable for light loads or in applications that can tolerate higher output ripple.

Since the output filter capacitor's ESR affects efficiency, use low-ESR capacitors for best performance. See Table 1 for component selection.

### Input Bypass Capacitors

The input bypass capacitor (C1) reduces peak currents drawn from the voltage source and also reduces noise at the voltage source caused by the switching action of the MAX1771. The input voltage source impedance determines the size of the capacitor required at the  $V+$  input. As with the output filter capacitor, a low-ESR capacitor is recommended. For output currents up to 1A, 68 $\mu\text{F}$  (C1) is adequate, although smaller bypass capacitors may also be acceptable.

Bypass the IC with a 0.1 $\mu\text{F}$  ceramic capacitor (C2) placed as close to the  $V+$  and GND pins as possible.

### Reference Capacitor

Bypass REF with a 0.1 $\mu\text{F}$  capacitor (C3). REF can source up to 100 $\mu\text{A}$  of current for external loads.

### Feed-Forward Capacitor

In adjustable output voltage and non-bootstrapped modes, parallel a 47pF to 220pF capacitor across  $R2$ , as shown in Figures 2 and 3. Choose the lowest capacitor value that insures stability; high capacitance values may degrade line regulation.

# 12V or Adjustable, High-Efficiency, Low IQ, Step-Up DC-DC Controller

Table 1. Component Suppliers

PRODUCTION	INDUCTORS	CAPACITORS	TRANSISTORS	DIODES
Surface Mount	Sumida CD54 series CDR125 series Coiltronics CTX20 series Coilcraft DO3316 series DO3340 series	Matsuo 267 series Sprague 595D series AVX TPS series	Siliconix Si9410DY Si9420DY (high voltage) Motorola MTP3055EL MTD20N03HDL MMFT3055ELT1 MTD6N1O MMBT8099LT1 MMBT8599LT1	Central Semiconductor CMPSH-3 CMPZ5240 Nihon EC11 FS1 series (high-speed silicon) Motorola MBRS1100T3 MMBZ5240BL
Through Hole	Sumida RCH855 series RCH110 series	Sanyo OS-CON series Nichicon PL series		Motorola 1N5817-1N5822 MUR115 (high voltage) MUR105 (high-speed silicon)

SUPPLIER	PHONE	FAX
AVX	USA: (803) 448-9411	(803) 448-1943
Central Semiconductor	USA: (516) 435-1110	(516) 435-1824
Coilcraft	USA: (708) 639-6400	(708) 639-1469
Coiltronics	USA: (516) 241-7876	(516) 241-9339
Matsuo	USA: (714) 969-2491 Japan: 81-6-337-6450	(714) 960-6492 81-6-337-6456
Motorola	USA: (800) 521-6274	(602) 952-4190
Nichicon	USA: (708) 843-7500	(708) 843-2798
Nihon	USA: (805) 867-2555	(805) 867-2556
Sanyo	USA: (619) 661-6835 Japan: 81-7-2070-1005	(619) 661-1055 81-7-2070-1174
Siliconix	USA: (800) 554-5565	(408) 970-3950
Sprague	USA: (603) 224-1961	(603) 224-1430
Sumida	USA: (708) 956-0666 Japan: 81-3-3607-5111	(708) 956-0702 81-3-3607-5144

# 12V or Adjustable, High-Efficiency, Low IQ, Step-Up DC-DC Controller

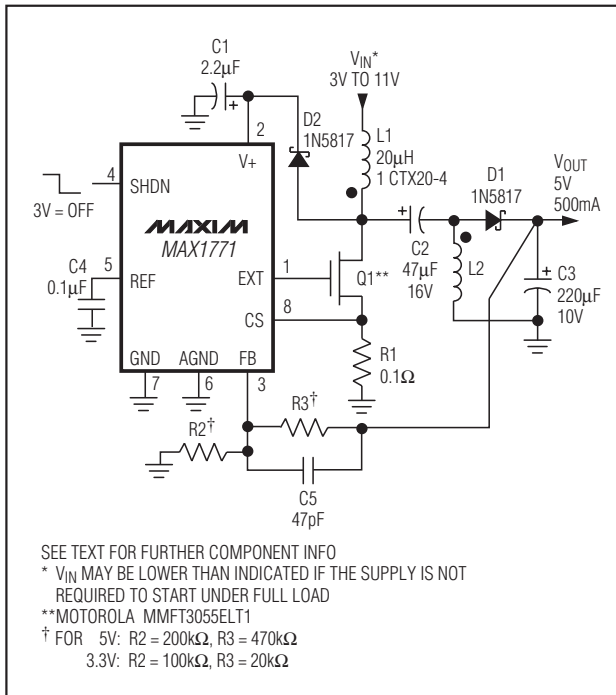

Figure 5. Step-Up/Down for a 5V/3.3V Output

## Applications Information

### Low Input Voltage Operation

When using a power supply that decays with time (such as a battery), the N-FET transistor will operate in its linear region when the voltage at EXT approaches the threshold voltage of the FET, dissipating excessive power. Prolonged operation in this mode may damage the FET. This effect is much more significant in non-bootstrapped mode than in bootstrapped mode, since bootstrapped mode typically provides much higher VGS voltages. To avoid this condition, make sure VEXT is above the  $V_{TH}$  of the FET, or use a voltage detector (such as the MAX8211) to put the IC in shutdown mode once the input supply voltage falls below a predetermined minimum value. Excessive loads with low input voltages can also cause this condition.

### Starting Up Under Load

The *Typical Operating Characteristics* show the Start-Up Voltage vs. Load Current graph for bootstrapped-mode operation. This graph depends on the type of power switch used. The MAX1771 is not designed to start up under full load in bootstrapped mode with low input voltages.

### Layout Considerations

Due to high current levels and fast switching waveforms, which radiate noise, proper PC board layout is essential. Protect sensitive analog grounds by using a star ground configuration. Minimize ground noise by connecting GND, the input bypass capacitor ground lead, and the output filter capacitor ground lead to a single point (star ground configuration). Also, minimize lead lengths to reduce stray capacitance, trace resistance, and radiated noise. Place input bypass capacitor C2 as close as possible to V+ and GND.

Excessive noise at the V+ input may falsely trigger the timing circuitry, resulting in short pulses at EXT. If this occurs it will have a negligible effect on circuit efficiency. If desired, place a 4.7µF directly across the V+ and GND pins (in parallel with the 0.1µF C2 bypass capacitor) to reduce the noise at V+.

### Other Application Circuits

#### 4 Cells to 5V (or 3 Cells to 3.3V), 500mA Step-Up/Down Converter

The circuit shown in Figure 5 generates 5V (or 3.3V) at 500mA with 85% efficiency, from an input voltage that varies above and below the output. The output couples to the switching circuitry via a capacitor. This configuration offers two advantages over flyback-transformer and step-up linear-regulator circuits: smooth regulation as the input passes through the output, and no output current in shutdown.

This circuit requires two inductors, which can be wound on one core with no regard to coupling since they do not work as a transformer. L1 and L2 can either be wound together (as with the Coiltronics CTX20-4) or kept as two separate inductors; both methods provide equal performance. Capacitors C2 and C3 should be low-ESR types for best efficiency. A 1µF ceramic capacitor will work at C2, but with about 3% efficiency loss. C2's voltage rating must be greater than the maximum input voltage. Also note that the LX switch must withstand a voltage equal to the sum of the input and output voltage; for example, when converting 11V to 5V, the switch must withstand 16V.

LX switch pulses are captured by Schottky diode D2 to boost V+ to ( $V_{OUT} + V_{IN}$ ). This improves efficiency with a low input voltage, but also limits the maximum input supply to 11V. If the input voltage does not fall below 4V and if a 3V logic threshold FET is used for Q1, you may omit D2 and connect V+ directly to the input supply.

#### 12V Output Buck/Boost

The circuit in Figure 6 generates 12V from a 4.5V to 16V input. Higher input voltages are possible if you

# 12V or Adjustable, High-Efficiency, Low IQ, Step-Up DC-DC Controller

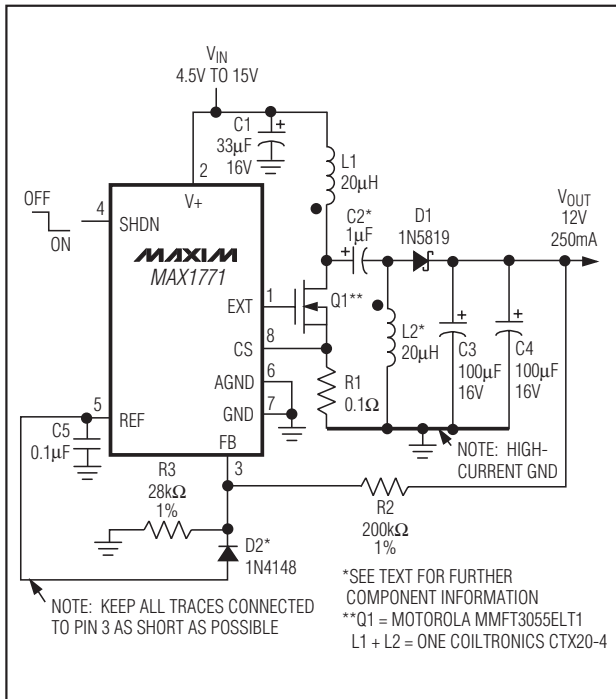

Figure 6. 12V Buck/Boost from a 4.5V to 15V Input

carefully observe the component voltage ratings, since some components must withstand the sum of the input and output voltage (27V in this case). The circuit operates as an AC-coupled boost converter, and does not change operating modes when crossing from buck to boost. There is no instability around a 12V input. Efficiency ranges from 85% at medium loads to about 82% at full load. Also, when shutdown is activated (SHDN high) the output goes to 0V and sources no current. A 1µF ceramic capacitor is used for C2. A larger capacitor value improves efficiency by about 1% to 3%. D2 ensures start-up for this AC-coupled configuration by overriding the MAX1771's Dual-Mode feature, which allows the use of preset internal or user-set external feedback. When operating in Dual-Mode, the IC first

tries to use internal feedback and looks to V+ for its feedback signal. However, since V+ may be greater than the internally set feedback (12V for the MAX1771), the IC may think the output is sufficiently high and not start. D2 ensures start-up by pulling FB above ground and forcing the external feedback mode. In a normal (not AC-coupled) boost circuit, D2 isn't needed, since the output and FB rise as soon as input power is applied.

### Transformerless -48V to +5V at 300mA

The circuit in Figure 7 uses a transformerless design to supply 5V at 300mA from a -30V to -75V input supply. The MAX1771 is biased such that its ground connections are made to the -48V input. The IC's supply voltage (at V+) is set to about 9.4V (with respect to -48V) by a zener-biased emitter follower (Q2). An N-channel FET (Q1) is driven in a boost configuration. Output regulation is achieved by a transistor (Q3), which level shifts a feedback signal from the 5V output to the IC's FB input. Conversion efficiency is typically 82%.

When selecting components, be sure that D1, Q1, Q2, Q3, and C6 are rated for the full input voltage plus a reasonable safety margin. Also, if D1 is substituted, it should be a fast-recovery type with a  $t_{rr}$  less than 30ns. R7, R9, C8, and D3 are optional and may be used to soft start the circuit to prevent excessive current surges at power-up.

### Battery-Powered LCD Bias Supply

The circuit in Figure 8 boosts two cells (2V min) to 24V for LCD bias or other positive output applications. Output power is boosted from the battery input, while V+ voltage for the MAX1771 is supplied by a 5V or 3.3V logic supply.

### 5V, 1A Boost Converter

The circuit in Figure 9 boosts a 2.7V to 5.5V input to a regulated 5V, 1A output for logic, RF power, or PCMCIA applications. Efficiency vs. load current is shown in the adjacent graph.



# 12V or Adjustable, High-Efficiency, Low IQ, Step-Up DC-DC Controller

MAX1771

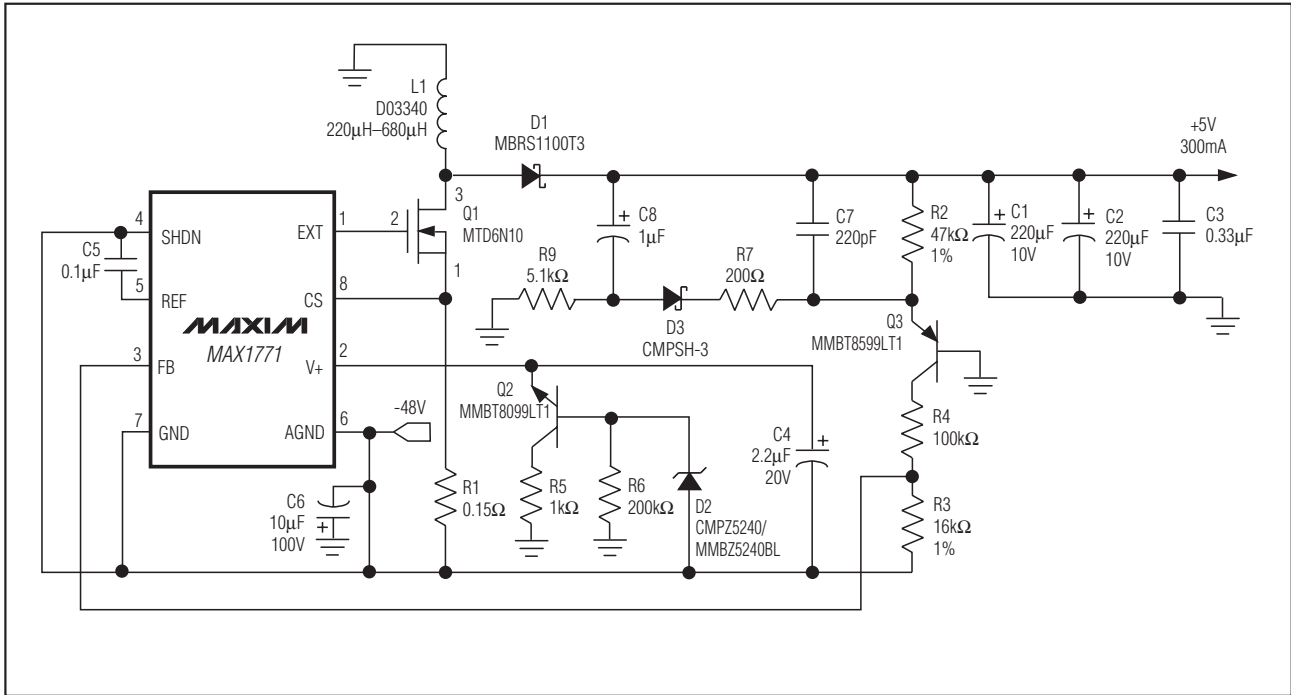

Figure 7. -48V Input to 5V Output at 300mA, Without a Transformer

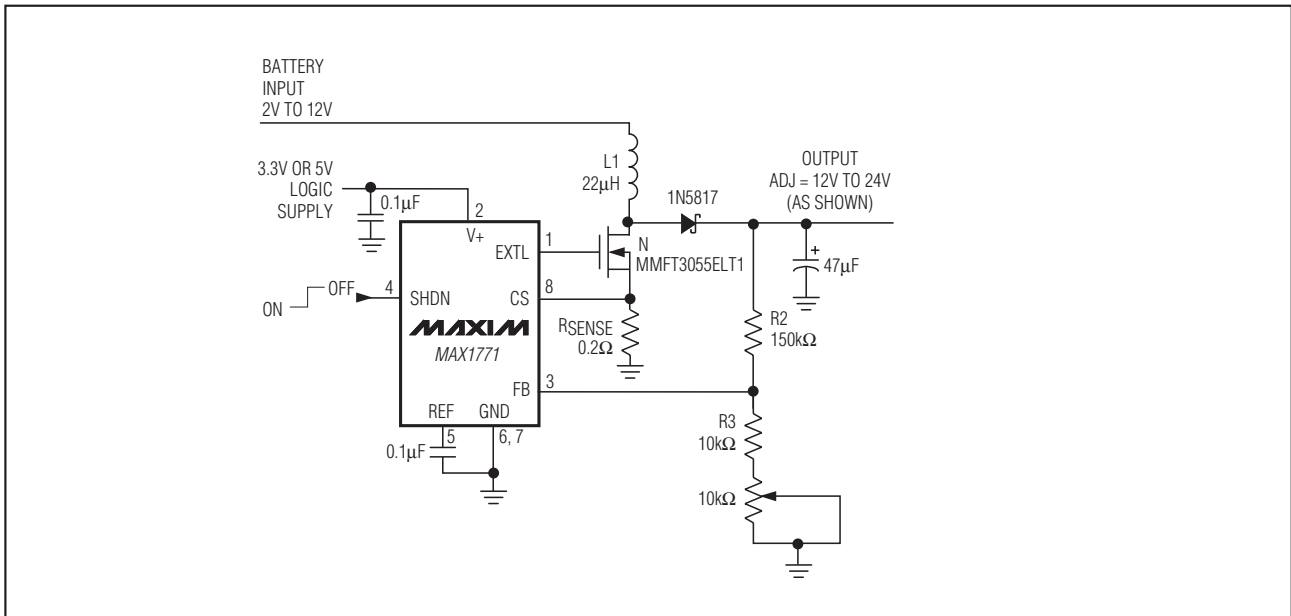

Figure 8. 2V Input to 24V Output LCD Bias



# 12V or Adjustable, High-Efficiency, Low IQ, Step-Up DC-DC Controller

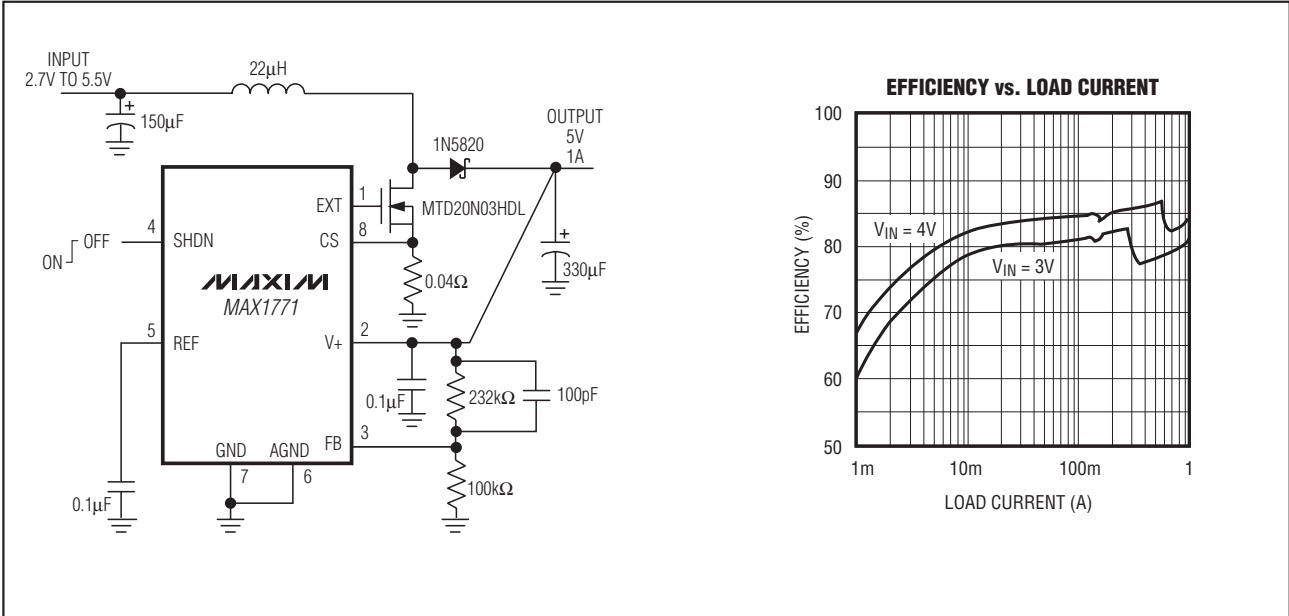
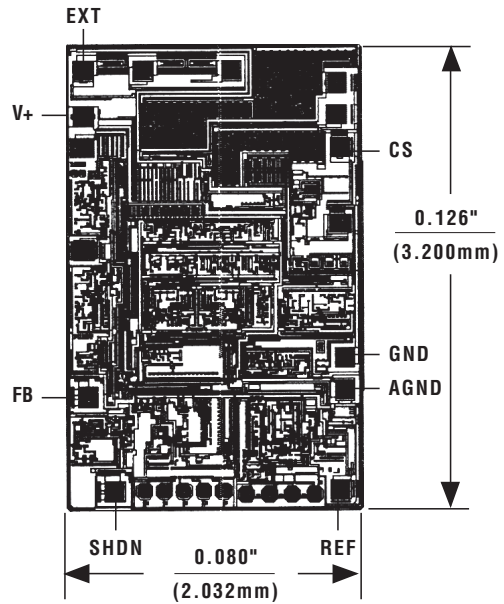

Figure 9. 5V/1A Boost Converter

## Chip Topography



TRANSISTOR COUNT: 501  
SUBSTRATE CONNECTED TO V+

Maxim cannot assume responsibility for use of any circuitry other than circuitry entirely embodied in a Maxim product. No circuit patent licenses are implied. Maxim reserves the right to change the circuitry and specifications without notice at any time.

16 **Maxim Integrated Products, 120 San Gabriel Drive, Sunnyvale, CA 94086 408-737-7600**