

80V - 80W DMOS AUDIO AMPLIFIER WITH MUTE/ST-BY

- VERY HIGH OPERATING VOLTAGE RANGE ($\pm 40V$)
- DMOS POWER STAGE
- HIGH OUTPUT POWER (UP TO 80W MUSIC POWER)
- MUTING/STAND-BY FUNCTIONS
- NO SWITCH ON/OFF NOISE
- NO BOUCHEROT CELLS
- VERY LOW DISTORTION
- VERY LOW NOISE
- SHORT CIRCUIT PROTECTION
- THERMAL SHUTDOWN

MULTIPOWER BCD TECHNOLOGY

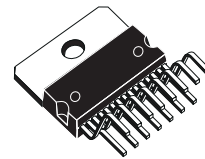

Multiwatt 15
ORDERING NUMBER: TDA7295

DESCRIPTION

The TDA7295 is a monolithic integrated circuit in Multiwatt15 package, intended for use as audio class AB amplifier in Hi-Fi field applications (Home Stereo, self powered loudspeakers, Top-class TV). Thanks to the wide voltage range and

to the high out current capability it is able to supply the highest power into both 4 Ω and 8 Ω loads even in presence of poor supply regulation, with high Supply Voltage Rejection.

The built in muting function with turn on delay simplifies the remote operation avoiding switching on-off noises.

Figure 1: Typical Application and Test Circuit

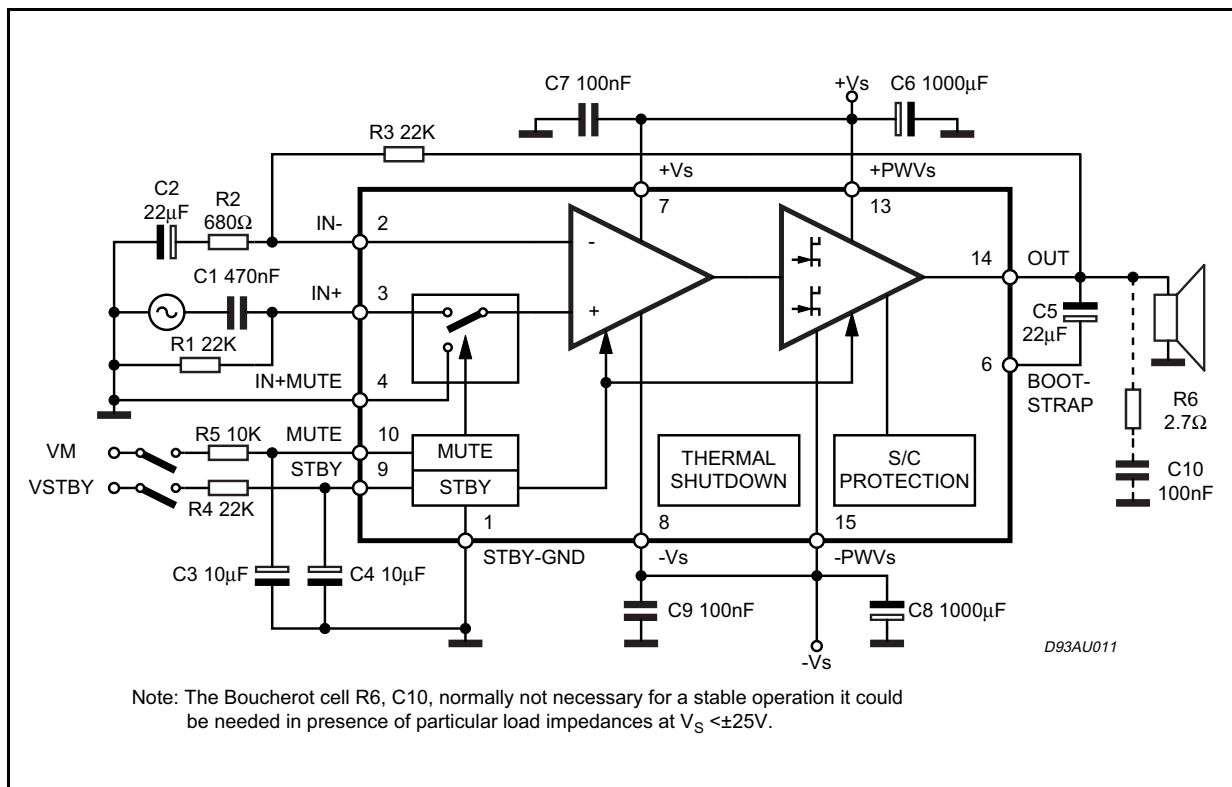

TDA7295

PIN CONNECTION (Top view)

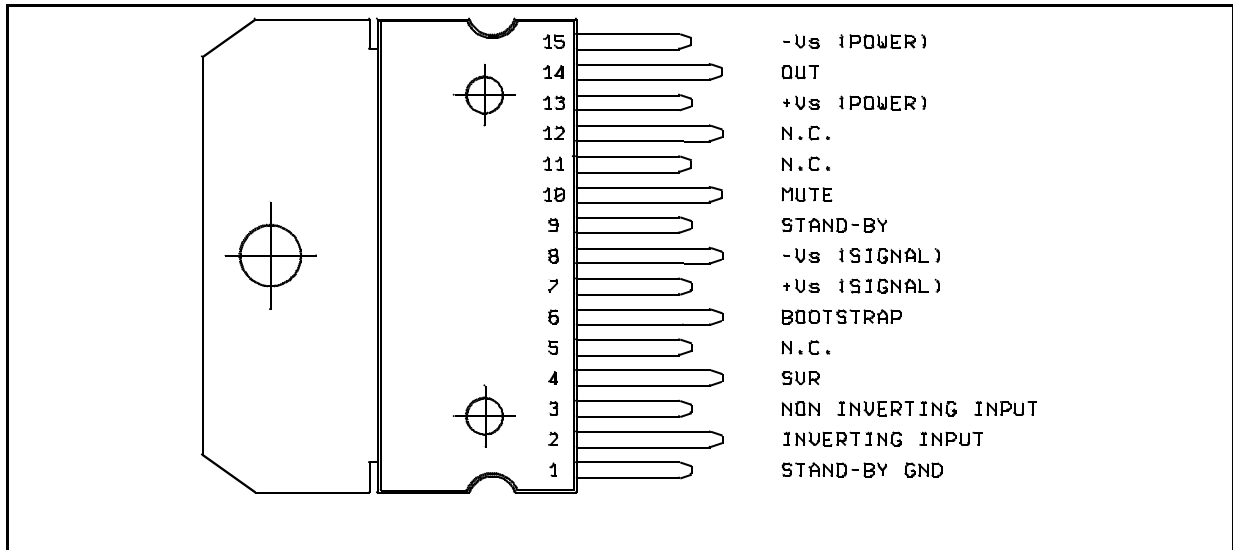

BLOCK DIAGRAM

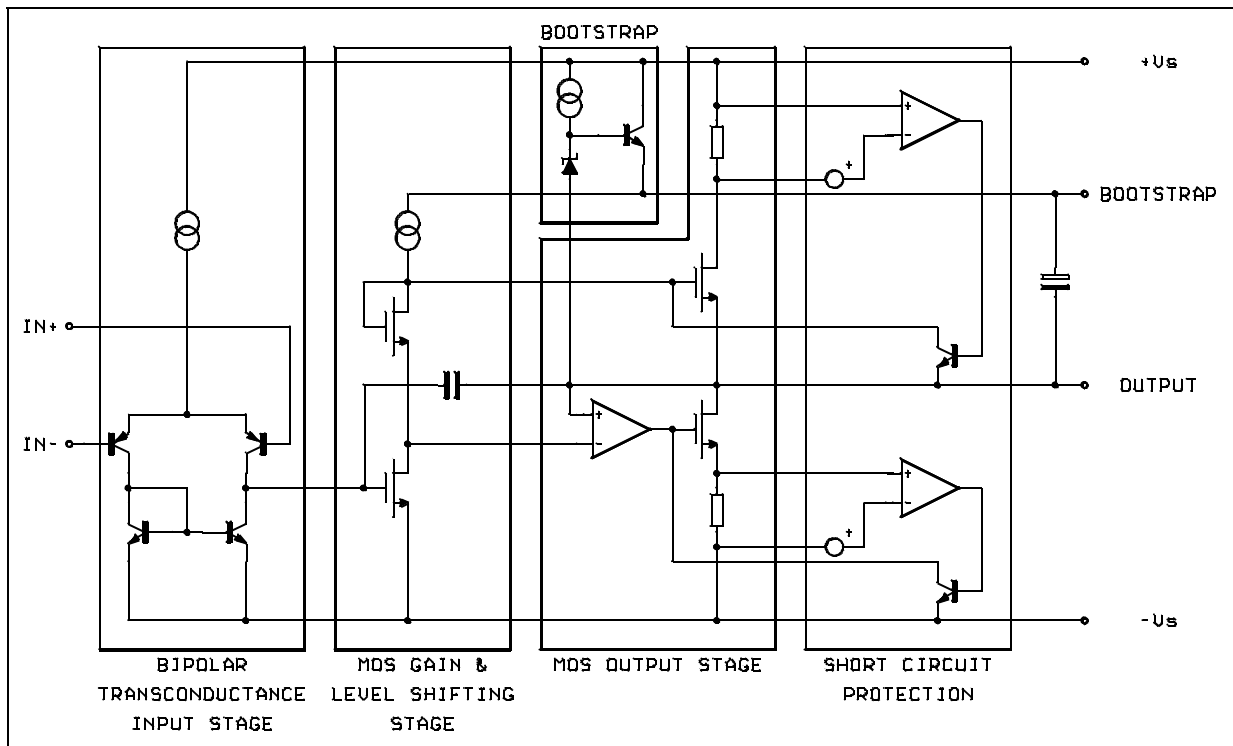

ABSOLUTE MAXIMUM RATINGS

Symbol	Parameter	Value	Unit
V _S	Supply Voltage	±40	V
I _o	Output Peak Current	6	A
P _{tot}	Power Dissipation T _{case} = 70°C	50	W
T _{op}	Operating Ambient Temperature Range	0 to 70	°C
T _{stg} , T _j	Storage and Junction Temperature	150	°C

THERMAL DATA

Symbol	Description	Value	Unit
$R_{th\ j-case}$	Thermal Resistance Junction-case	Max	1.5 °C/W

ELECTRICAL CHARACTERISTICS (Refer to the Test Circuit $V_S = \pm 30V$, $R_L = 8\Omega$, $G_V = 30dB$; $R_g = 50\ \Omega$; $T_{amb} = 25^\circ C$, $f = 1\ kHz$; unless otherwise specified.

Symbol	Parameter	Test Condition	Min.	Typ.	Max.	Unit
V_S	Operating Supply Range		± 10		± 40	V
I_q	Quiescent Current		20	30	65	mA
I_b	Input Bias Current				500	nA
V_{OS}	Input Offset Voltage				± 10	mV
I_{OS}	Input Offset Current				± 100	nA
P_O	RMS Continuous Output Power	$d = 0.5\%$: $V_S = \pm 30V$, $R_L = 8\Omega$ $V_S = \pm 26V$, $R_L = 6\Omega$ $\zeta_S = \pm 22V$, $R_L = 4\Omega$	45 45 45	50 50 50		W W W
	Music Power (RMS) (*) $\Delta t = 1s$	$d = 10\%$; $R_L = 8\Omega$; $V_S = \pm 34V$ (***) $R_L = 4\Omega$; $V_S = \pm 26V$		80 80		W W
d	Total Harmonic Distortion (**)	$P_O = 5W$; $f = 1kHz$ $P_O = 0.1$ to $30W$; $f = 20Hz$ to $20kHz$		0.005	0.1	% %
		$V_S = \pm 22V$, $R_L = 4\Omega$: $P_O = 5W$; $f = 1kHz$ $P_O = 0.1$ to $30W$; $f = 20Hz$ to $20kHz$		0.01	0.1	% %
SR	Slew Rate		7	10		V/ μs
G_V	Open Loop Voltage Gain			80		dB
G_V	Closed Loop Voltage Gain		24	30	40	dB
e_N	Total Input Noise	A = curve $f = 20Hz$ to $20kHz$		1 2	5	μV μV
f_L, f_H	Frequency Response (-3dB)	$P_O = 1W$	20Hz to 20kHz			
R_i	Input Resistance		100			k Ω
SVR	Supply Voltage Rejection	$f = 100Hz$; $V_{ripple} = 0.5V_{rms}$	60	75		dB
T_S	Thermal Shutdown			145		°C
STAND-BY FUNCTION (Ref: $-V_S$ or GND)						
$V_{ST\ on}$	Stand-by on Threshold				1.5	V
$V_{ST\ off}$	Stand-by off Threshold		3.5			V
ATT_{st-by}	Stand-by Attenuation		70	90		dB
$I_{q\ st-by}$	Quiescent Current @ Stand-by			1	3	mA
MUTE FUNCTION (Ref: $-V_S$ or GND)						
V_{Mon}	Mute on Threshold				1.5	V
V_{Moff}	Mute off Threshold		3.5			V
ATT_{mute}	Mute Attenuation		60	80		dB

Note (*):

MUSIC POWER is the maximal power which the amplifier is capable of producing across the rated load resistance (regardless of non linearity) 1 sec after the application of a sinusoidal input signal of frequency 1KHz.

Note ():** Tested with optimized Application Board (see fig. 2)

Note (*):** Limited by the max. allowable out current

Figure 2: P.C.B. and components layout of the circuit of figure 1. (1:1 scale)

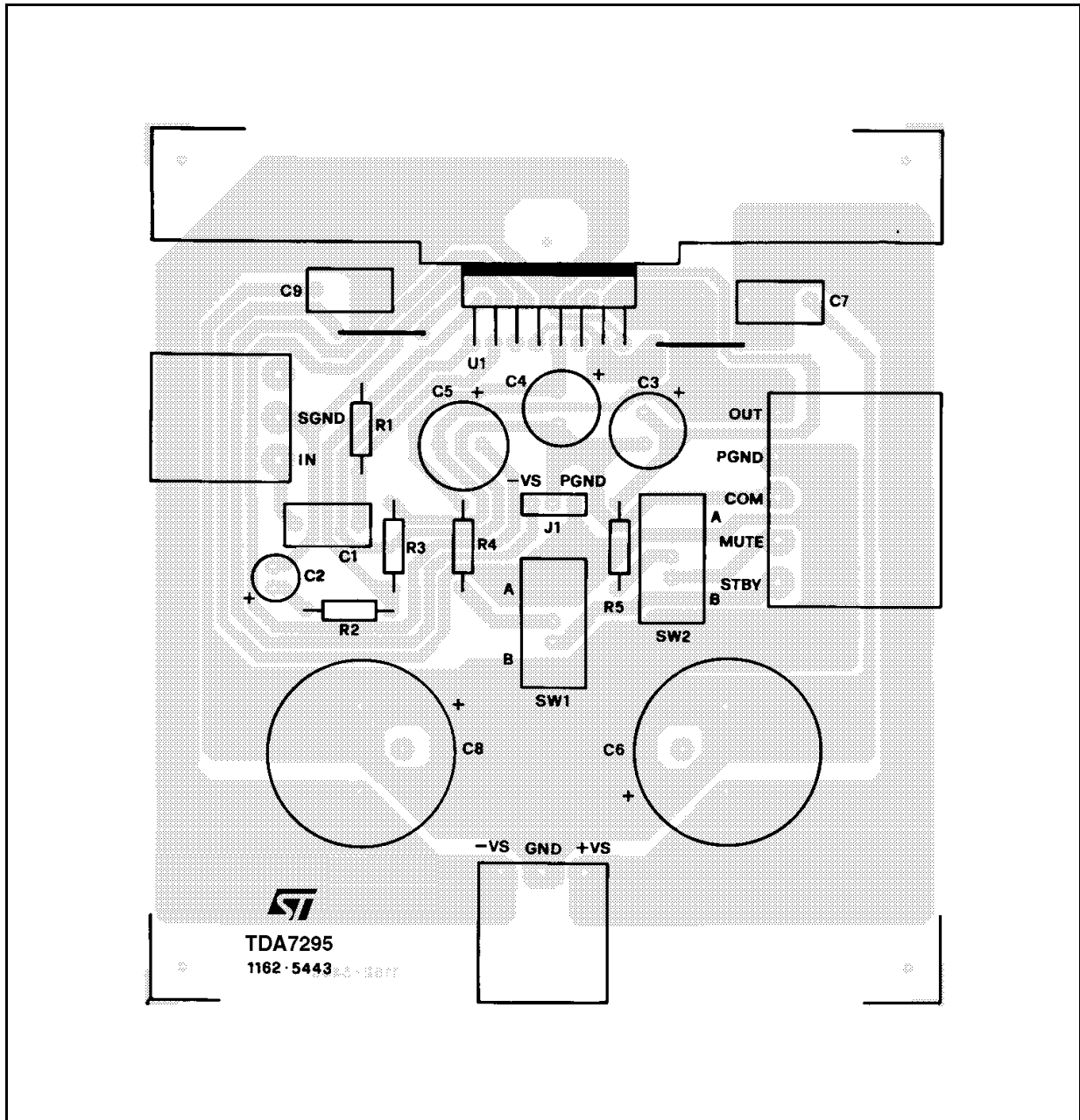

Note:

The Stand-by and Mute functions can be referred either to GND or -VS.
 On the P.C.B. is possible to set both the configuration through the jumper J1.

APPLICATION SUGGESTIONS (see Test and Application Circuits of the Fig. 1)

The recommended values of the external components are those shown on the application circuit of Figure 1. Different values can be used; the following table can help the designer.

COMPONENTS	SUGGESTED VALUE	PURPOSE	LARGER THAN SUGGESTED	SMALLER THAN SUGGESTED
R1 (*)	22k	INPUT RESISTANCE	INCREASE INPUT IMPEDANCE	DECREASE INPUT IMPEDANCE
R2	680 Ω	CLOSED LOOP GAIN SET TO 30dB (**)	DECREASE OF GAIN	INCREASE OF GAIN
R3 (*)	22k		INCREASE OF GAIN	DECREASE OF GAIN
R4	22k	ST-BY TIME CONSTANT	LARGER ST-BY ON/OFF TIME	SMALLER ST-BY ON/OFF TIME; POP NOISE
R5	10k	MUTE TIME CONSTANT	LARGER MUTE ON/OFF TIME	SMALLER MUTE ON/OFF TIME
C1	0.47 μ F	INPUT DC DECOUPLING		HIGHER LOW FREQUENCY CUTOFF
C2	22 μ F	FEEDBACK DC DECOUPLING		HIGHER LOW FREQUENCY CUTOFF
C3	10 μ F	MUTE TIME CONSTANT	LARGER MUTE ON/OFF TIME	SMALLER MUTE ON/OFF TIME
C4	10 μ F	ST-BY TIME CONSTANT	LARGER ST-BY ON/OFF TIME	SMALLER ST-BY ON/OFF TIME; POP NOISE
C5	22 μ F	BOOTSTRAPPING		SIGNAL DEGRADATION AT LOW FREQUENCY
C6, C8	1000 μ F	SUPPLY VOLTAGE BYPASS		DANGER OF OSCILLATION
C7, C9	0.1 μ F	SUPPLY VOLTAGE BYPASS		DANGER OF OSCILLATION

(*) R1 = R3 FOR POP OPTIMIZATION

(**) CLOSED LOOP GAIN HAS TO BE ≥ 24 dB

TYPICAL CHARACTERISTICS

(Application Circuit of fig 1 unless otherwise specified)

Figure 3: Output Power vs. Supply Voltage.

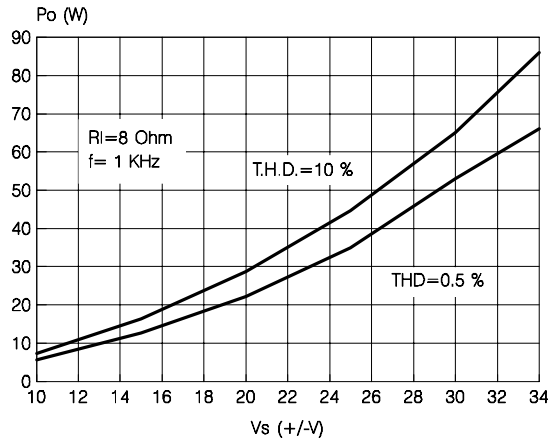

Figure 4: Distortion vs. Output Power

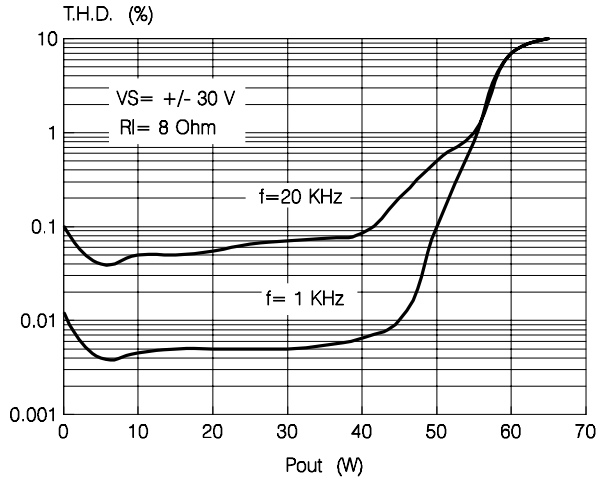

Figure 5: Output Power vs. Supply Voltage

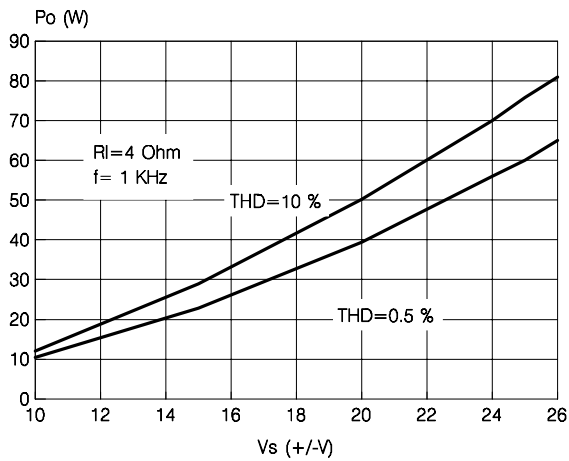

Figure 6: Distortion vs. Output Power

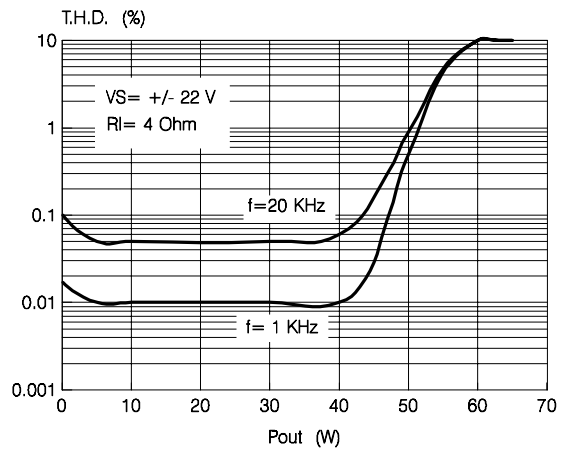

Figure 7: Distortion vs. Frequency

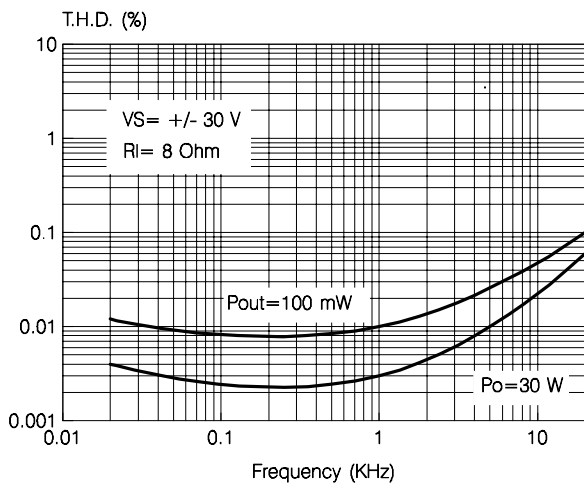
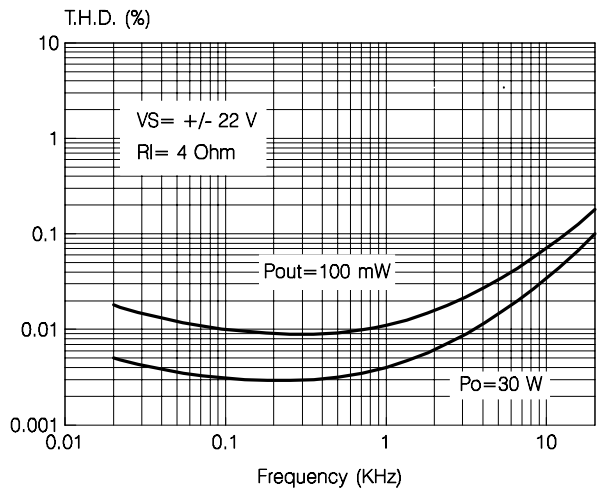

Figure 8: Distortion vs. Frequency



TYPICAL CHARACTERISTICS (continued)

Figure 9: Quiescent Current vs. Supply Voltage

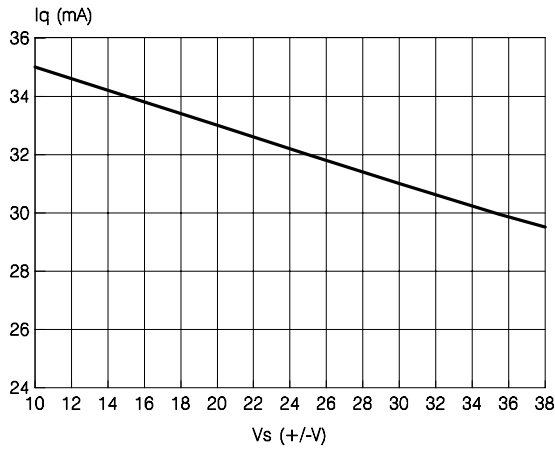

Figure 10: Supply Voltage Rejection vs. Frequency

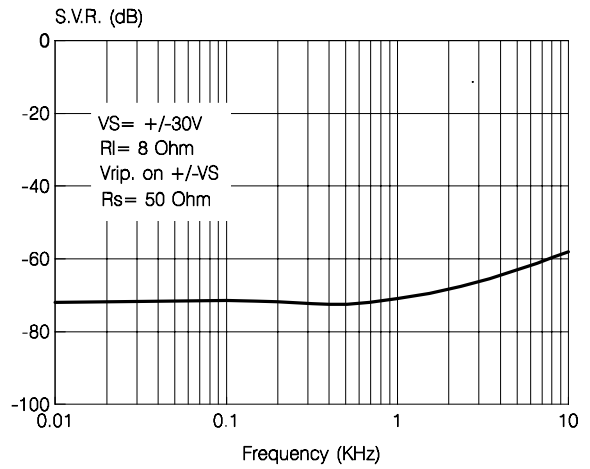

Figure 11: Mute Attenuation vs. V_{pin10}

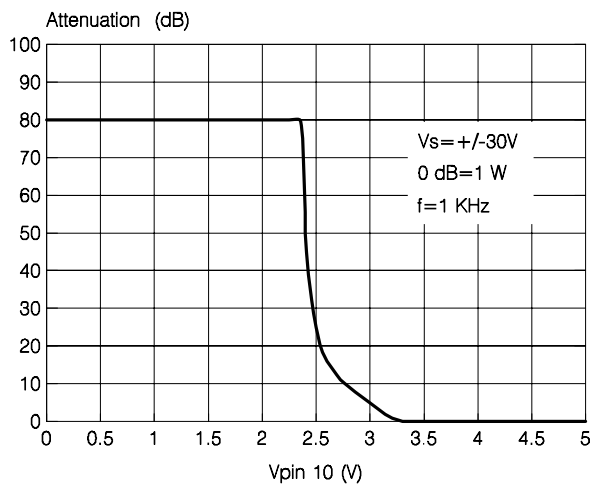

Figure 12: St-by Attenuation vs. V_{pin9}

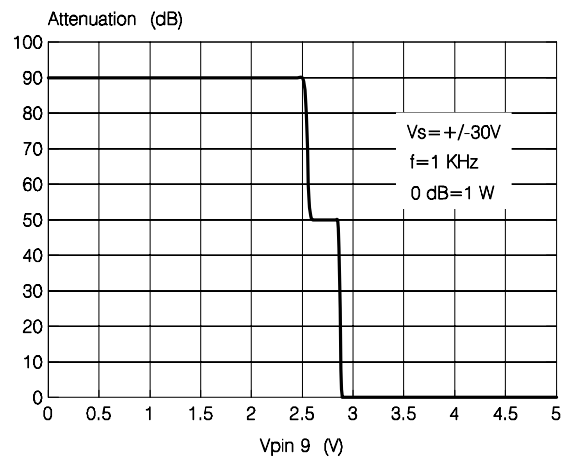

Figure 13: Power Dissipation vs. Output Power

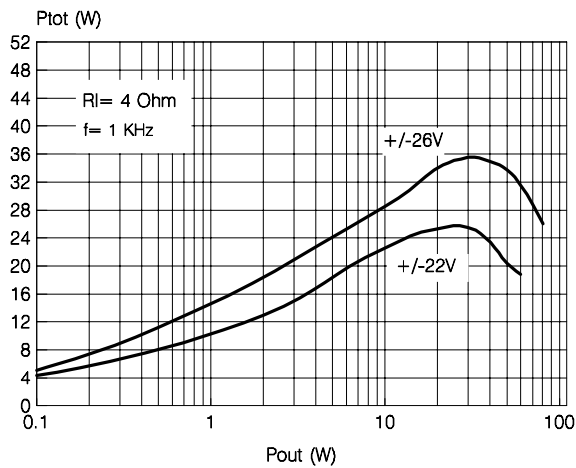
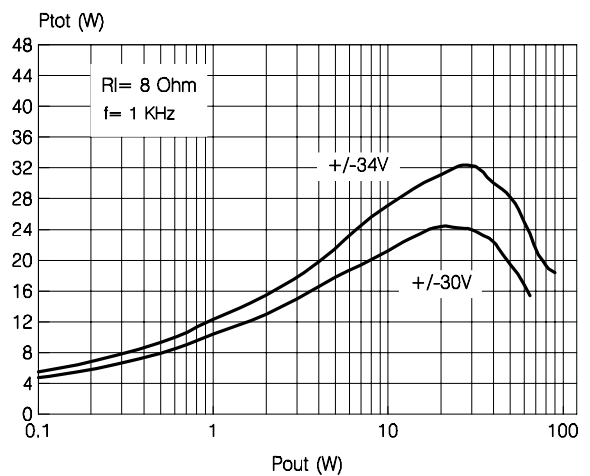

Figure 14: Power Dissipation vs. Output Power



INTRODUCTION

In consumer electronics, an increasing demand has arisen for very high power monolithic audio amplifiers able to match, with a low cost the performance obtained from the best discrete designs.

The task of realizing this linear integrated circuit in conventional bipolar technology is made extremely difficult by the occurrence of 2nd breakdown phenomenon. It limits the safe operating area (SOA) of the power devices, and as a consequence, the maximum attainable output power, especially in presence of highly reactive loads.

Moreover, full exploitation of the SOA translates into a substantial increase in circuit and layout complexity due to the need for sophisticated protection circuits.

To overcome these substantial drawbacks, the use of power MOS devices, which are immune from secondary breakdown is highly desirable.

The device described has therefore been developed in a mixed bipolar-MOS high voltage technology called BCD 100.

1) Output Stage

The main design task one is confronted with while developing an integrated circuit as a power operational amplifier, independently of the technology used, is that of realising the output stage.

The solution shown as a principle schematic by Fig 15 represents the DMOS unity-gain output buffer of the TDA7295.

This large-signal, high-power buffer must be capable of handling extremely high current and voltage levels while maintaining acceptably low harmonic distortion and good behaviour over frequency response; moreover, an accurate control of quiescent current is required.

A local linearizing feedback, provided by differential amplifier A, is used to fulfill the above requirements, allowing a simple and effective quiescent current setting.

Proper biasing of the power output transistors alone is however not enough to guarantee the absence of crossover distortion.

While a linearization of the DC transfer characteristic of the stage is obtained, the dynamic behaviour of the system must be taken into account.

A significant aid in keeping the distortion contributed by the final stage as low as possible is provided by the compensation scheme, which exploits the direct connection of the Miller capacitor at the amplifier's output to introduce a local AC feedback path enclosing the output stage itself.

2) Protections

In designing a power IC, particular attention must be reserved to the circuits devoted to protection of the device from short circuit or overload conditions.

Due to the absence of the 2nd breakdown phenomenon, the SOA of the power DMOS transistors is delimited only by a maximum dissipation curve dependent on the duration of the applied stimulus.

In order to fully exploit the capabilities of the power transistors, the protection scheme implemented in this device combines a conventional SOA protection circuit with a novel local temperature sensing technique which "dynamically" controls the maximum dissipation.

Figure 15: Principle Schematic of a DMOS unity-gain buffer.

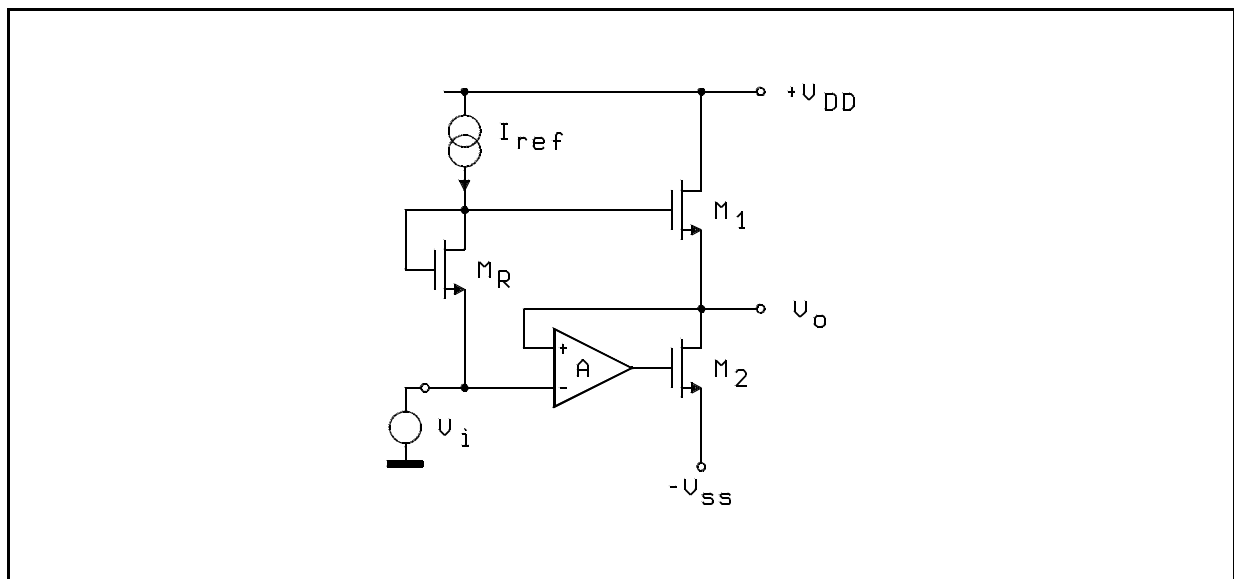
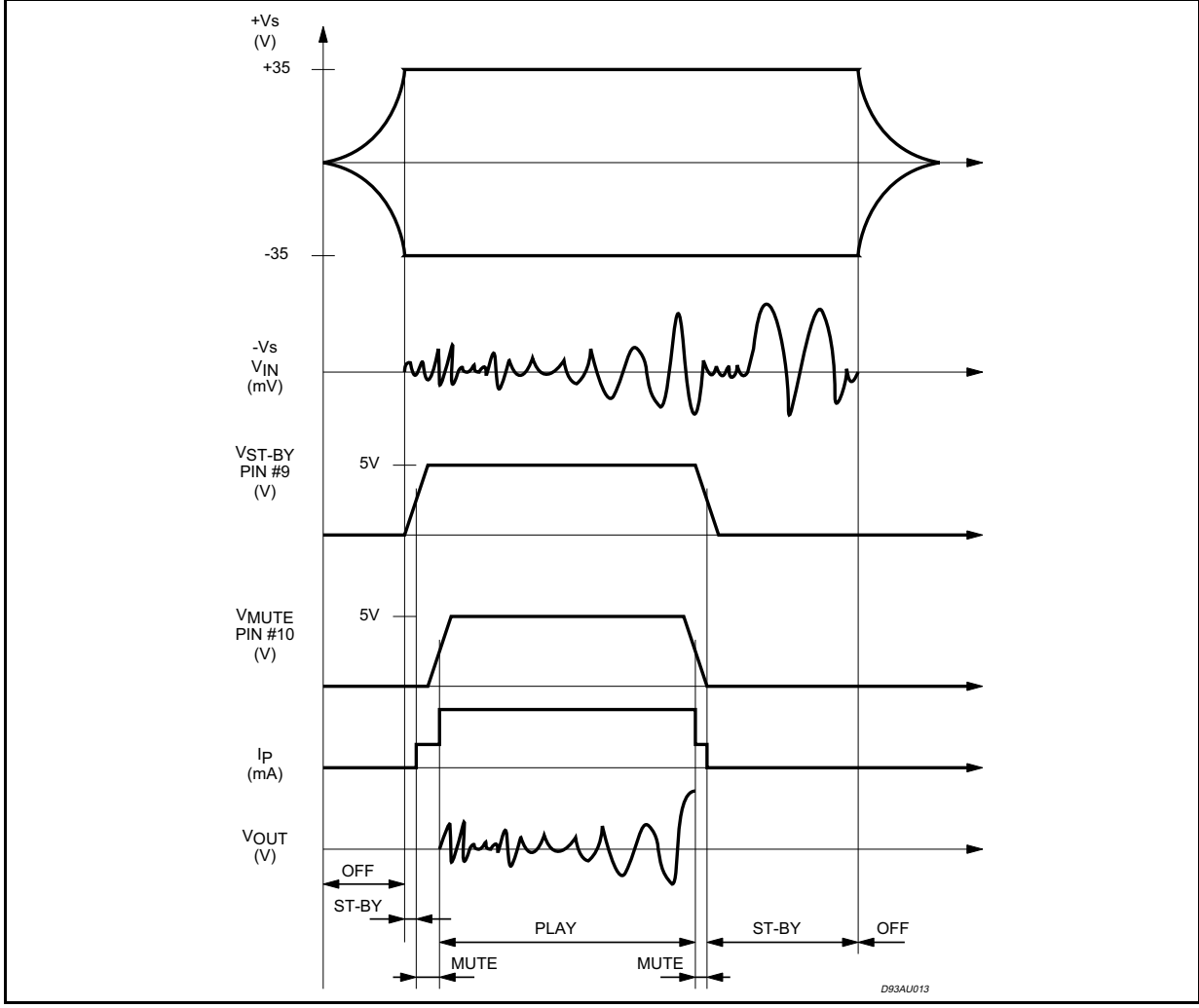

Figure 16: Turn ON/OFF Suggested Sequence



In addition to the overload protection described above, the device features a thermal shutdown circuit which initially puts the device into a muting state (@ $T_j = 145^\circ\text{C}$) and then into stand-by (@

$T_j = 150^\circ\text{C}$). Full protection against electrostatic discharges on every pin is included.

Figure 17: Single Signal ST-BY/MUTE Control Circuit

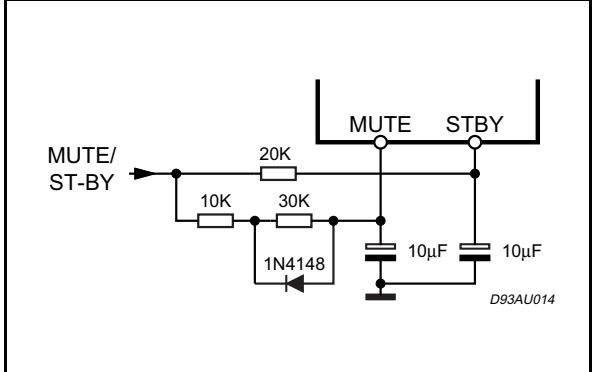

3) Other Features

The device is provided with both stand-by and mute functions, independently driven by two CMOS logic compatible input pins.

The circuits dedicated to the switching on and off of the amplifier have been carefully optimized to avoid any kind of uncontrolled audible transient at the output.

The sequence that we recommend during the ON/OFF transients is shown by Figure 16.

The application of figure 17 shows the possibility of using only one command for both st-by and mute functions. On both the pins, the maximum applicable range corresponds to the operating supply voltage.



BRIDGE APPLICATION

Another application suggestion is the BRIDGE configuration, where two TDA7295 are used, as shown by the schematic diagram of figure 25.

In this application, the value of the load must not be lower than 8 Ohm for dissipation and current capability reasons.

A suitable field of application includes HI-FI/TV subwoofers realisations.

The main advantages offered by this solution are:

- High power performances with limited supply voltage level.
- Considerably high output power even with high load values (i.e. 16 Ohm).

The characteristics shown by figures 20 and 21, measured with loads respectively 8 Ohm and 16 Ohm.

With $R_l = 8 \text{ Ohm}$, $V_s = \pm 22\text{V}$ the maximum output power obtainable is 100W, while with $R_l = 16 \text{ Ohm}$, $V_s = \pm 30\text{V}$ the maximum P_{out} is 100W.

Figure 18: Bridge Application Circuit

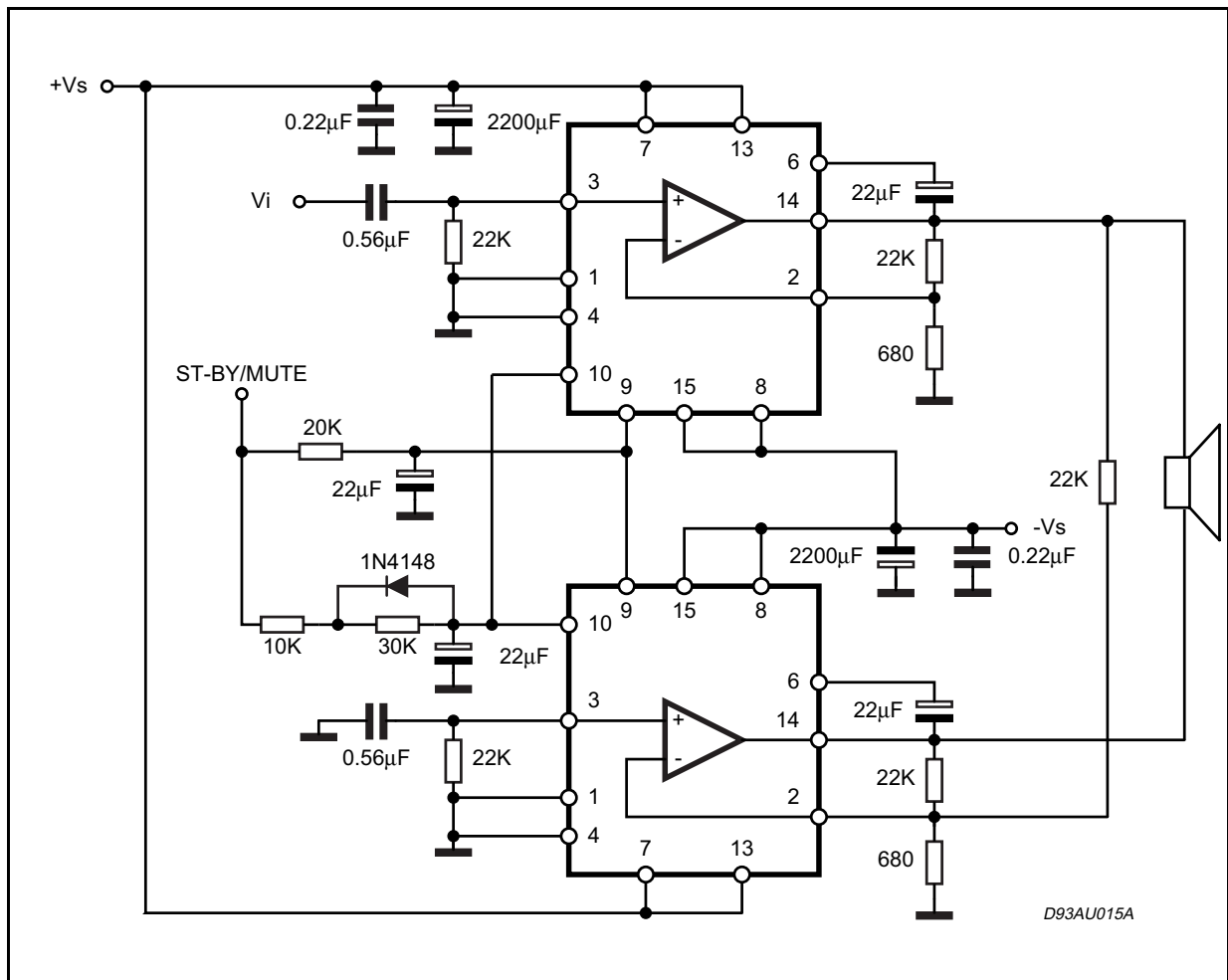

Figure 19: Frequency Response of the Bridge Application

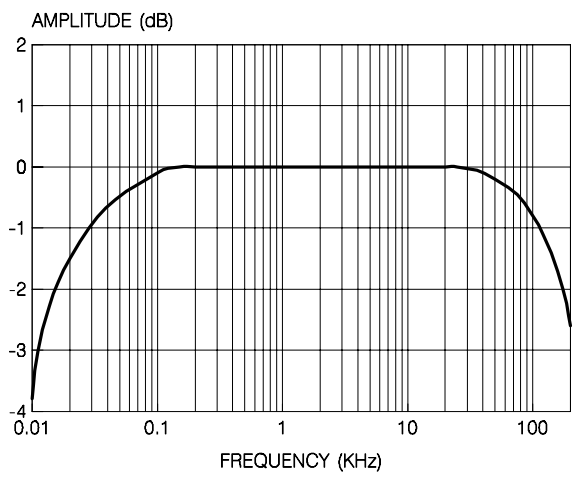

Figure 20: Distortion vs. Output Power

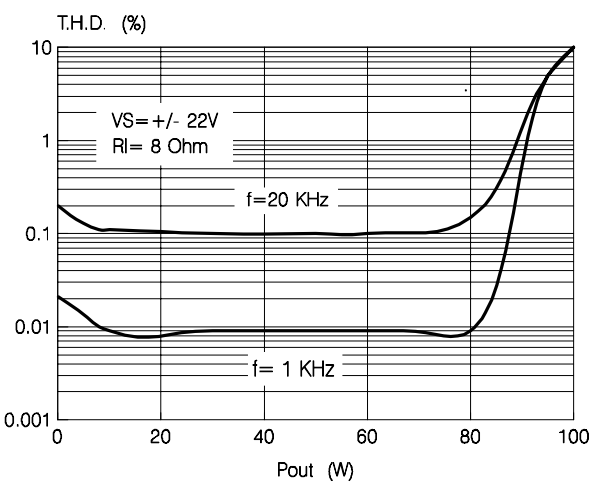
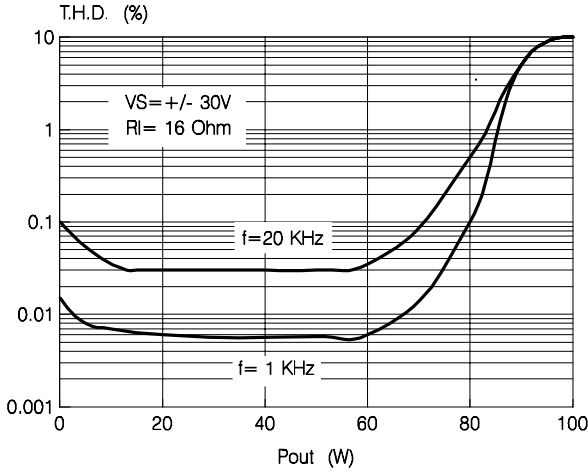
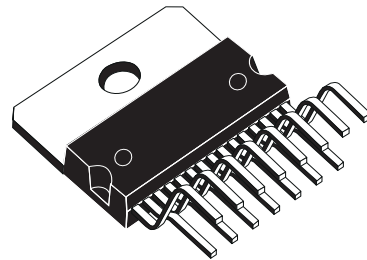

Figure 21: Distortion vs. Output Power



DIM.	mm			inch		
	MIN.	TYP.	MAX.	MIN.	TYP.	MAX.
A			5			0.197
B			2.65			0.104
C			1.6			0.063
D		1			0.039	
E	0.49		0.55	0.019		0.022
F	0.66		0.75	0.026		0.030
G	1.02	1.27	1.52	0.040	0.050	0.060
G1	17.53	17.78	18.03	0.690	0.700	0.710
H1	19.6			0.772		
H2			20.2			0.795
L	21.9	22.2	22.5	0.862	0.874	0.886
L1	21.7	22.1	22.5	0.854	0.870	0.886
L2	17.65		18.1	0.695		0.713
L3	17.25	17.5	17.75	0.679	0.689	0.699
L4	10.3	10.7	10.9	0.406	0.421	0.429
L7	2.65		2.9	0.104		0.114
M	4.25	4.55	4.85	0.167	0.179	0.191
M1	4.63	5.08	5.53	0.182	0.200	0.218
S	1.9		2.6	0.075		0.102
S1	1.9		2.6	0.075		0.102
Dia1	3.65		3.85	0.144		0.152

OUTLINE AND MECHANICAL DATA



Multiwatt15 V

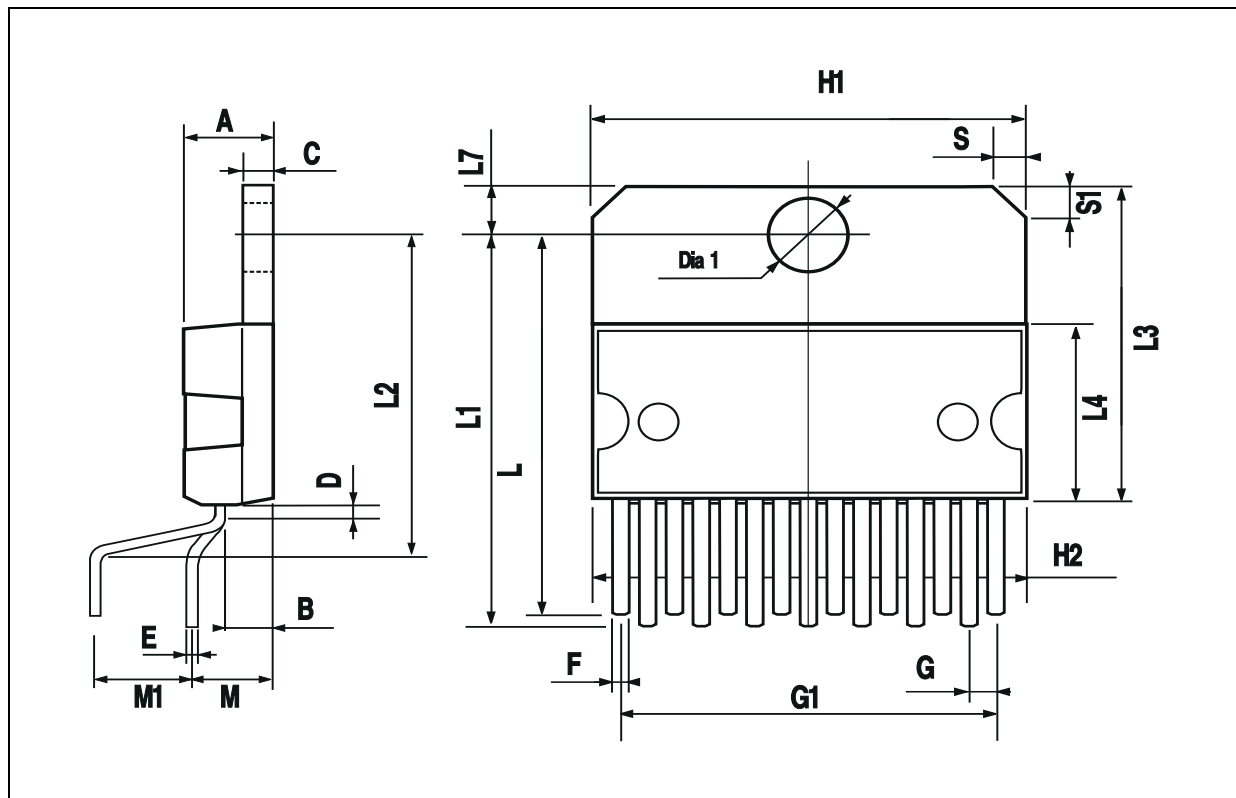

Information furnished is believed to be accurate and reliable. However, STMicroelectronics assumes no responsibility for the consequences of use of such information nor for any infringement of patents or other rights of third parties which may result from its use. No license is granted by implication or otherwise under any patent or patent rights of STMicroelectronics. Specification mentioned in this publication are subject to change without notice. This publication supersedes and replaces all information previously supplied. STMicroelectronics products are not authorized for use as critical components in life support devices or systems without express written approval of STMicroelectronics.

The ST logo is a registered trademark of STMicroelectronics

© 2003 STMicroelectronics – Printed in Italy – All Rights Reserved

STMicroelectronics GROUP OF COMPANIES

Australia - Brazil - Canada - China - Finland - France - Germany - Hong Kong - India - Israel - Italy - Japan - Malaysia - Malta - Morocco - Singapore - Spain - Sweden - Switzerland - United Kingdom - United States.

<http://www.st.com>

