

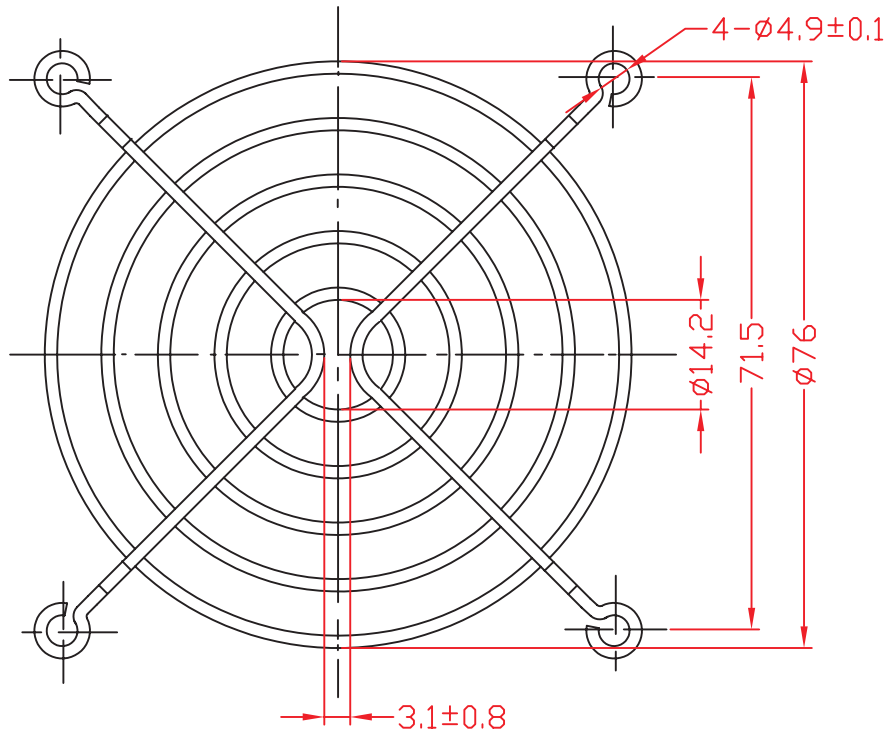

EDITION	DATE	REVISION RECORD	REVISION NO.	APPROVED

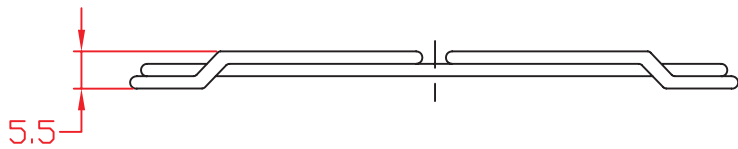

NOTES:

- 1.MATERIAL:C1008 BRIGHT BASIC WIRE.
- 2.FINISH:BRIGHT NICKEL CHROME.Cr3⁺
- 3.(1)RINGS ARE ø 1.8mm.
(2)RIBS ARE ø 1.8mm.
- 4.WELD JOINTS TO WITHSTAND 88 LBS PULL FORCE.
- 5.SPACING BETWEEN RINGS TO BE EUQIDISTANT 5.48mm.
- 6.GENERAL TOLERANCE UNLESS NOTED:±0.5mm.
- 7.PART MEETS ø 6.35mmPLUG GAUGE TEST.
- 8.UNIT:mm.



APPROVED	CHECKED	DESIGNED	DRAWN	 	MATERIAL	SEE NOTES	TITLE	FAN GUARD
				SCALE	FINISH	SEE NOTES	PART NO.	0 REV
				DRAWING DATE				